



AIR PREPARATION PRESSURE REGULATORS

PRODUCT CATALOG



PRESSURE REGULATORS – KEY FEATURES

- Two design options available:
Piston design for highest air flow
Diaphragm design for high sensitivity and quick response
- Modular or In-line Mounting options
- Pressure Gauge included
- Removable Adjusting Knob for tamper resistance
- Self-relieving or non-relieving options
- Reverse Flow option available on some regulator models
- T-Handle option available on some regulator models

REGULATOR TYPE/SERIES	AVAILABLE PORT SIZES										MOUNTING		FLOW	CONSTRUCTION		OPTIONS					Page	
	1/8	1/4	3/8	1/2	3/4	1	1-1/4	1-1/2	2	3	IN-LINE	MODULAR	MAX FLOW (scfm)	PISTON	DIAPHRAGM	SELF RELIEVING	NON RELIEVING	REVERSE FLOW	T-HANDLE	LOCKING KNOB		
STANDARD REGULATORS																						
RIGHT-ANGLE													55									3
BANTAM													23									4
MINIATURE													40									5
MID-SIZE													4040									6
MD3™													120									7
FULL-SIZE													155									8
MD4™													220									9
HIGH-CAPACITY													800									10
HIGH-PRESSURE REGULATORS																						
HIGH-PRESSURE													70									11
PRECISION REGULATORS																						
MINIATURE													4									12
FULL-SIZE													155									13
MD4™													170									14
HIGH-CAPACITY													800									15
REMOTE PILOT REGULATORS																						
FULL-SIZE													155									16 - 18
MD4™													190									19
HIGH-CAPACITY													4000									20 - 23
RELIEF VALVES																						
MINIATURE													40									24
HIGH-FLOW													450									25
PROPORTIONAL VALVES																						
RER Series													1000									26
RB-RER Series													4000									27
Accessories																				28 - 30		

In-line Pressure Regulators – RIGHT-ANGLE Series



Port Sizes: 1/8, 1/4, 3/8, 1/2 – Flow to 55 scfm

Models with Threaded Banjo

Port Size		Port Thread	Model Number	Dimensions inches (mm)		Tightening Torque Max. Ft-lb (Nm)
Port 1 (female threads)	Port 2 (male threads)			A	B	
1/8	1/8	NPT	5214A1010	0.7 (17)	2.9 (74)	7.38 (10)
1/4	1/4	NPT	5214A2010	0.7 (17)	3.2 (81)	8.85 (12)
3/8	3/8	NPT	5214A3010	0.9 (22)	3.5 (88)	14.75 (20)
1/2	1/2	NPT	5214A4010	1.1 (27)	3.5 (89)	22.13 (30)
1/8	1/8	G	D5214A1010	0.7 (17)	2.9 (74)	11.06 (15)
1/4	1/4	G	D5214A2010	0.7 (17)	3.2 (81)	14.75 (20)
3/8	3/8	G	D5214A3010	0.9 (22)	3.5 (88)	22.13 (20)
1/2	1/2	G	D5214A4010	1.1 (27)	3.5 (89)	22.50 (30)



ISO Symbol Regulator Self-Relieving



Models with Push-to-Connect Fitting

Port Size		Model Number	Dimensions inches (mm)		Tightening Torque Max. Ft-lb (Nm)
Port 1* (tube size)	Port 2** (thread size)		A	B	
1/4"	1/8 NPT	5214A1120	0.7 (17)	2.9 (73)	11.06 (15)
1/4"	1/4 NPT	5214A2120	0.7 (17)	3.2 (81)	14.75 (20)
3/8"	1/4 NPT	5214A2130	0.7 (17)	3.2 (81)	14.75 (20)
3/8"	3/8 NPT	5214A3130	0.9 (22)	3.5 (88)	22.13 (30)
4 mm	1/8 G	D5214A1140	0.5 (13)	2.9 (73)	7.38 (10)
6 mm	1/8 G	D5214A1160	0.5 (13)	2.9 (73)	7.38 (10)
8 mm	1/8 G	D5214A1180	0.5 (13)	2.9 (73)	7.38 (10)
6 mm	1/4 G	D5214A2160	0.7 (17)	3.2 (81)	8.85 (12)
8 mm	1/4 G	D5214A2180	0.7 (17)	3.2 (81)	8.85 (12)
10 mm	1/4 G	D5214A2110	0.7 (17)	3.2 (81)	8.85 (12)
8 mm	3/8 G	D5214A3180	0.9 (22)	3.5 (88)	14.75 (20)
10 mm	3/8 G	D5214A3110	0.9 (22)	3.5 (88)	14.75 (20)

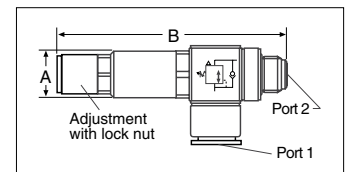
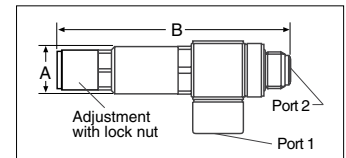

Port 1 tubing size in inches (") or millimeters (mm). ** Port 2 threads are male.

FLOW CHARTS

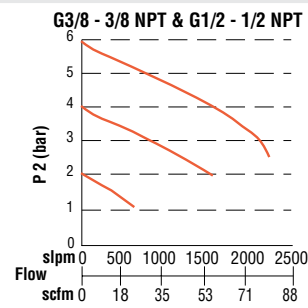
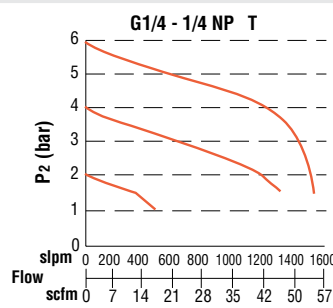
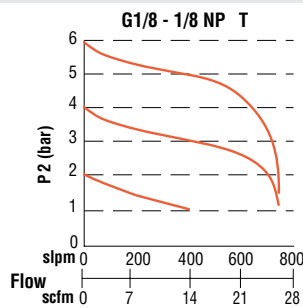

STANDARD SPECIFICATIONS

Construction Design	Self-relieving	
Temperature	Ambient	15° to 160°F (-10° to 70°C)
	Media	
Fluid Media	Filtered air	
Operating Pressure	15 to 240 psig (1 to 17 bar)	
	Regulated Pressure Range	15 to 120 psig (1 to 8 bar).
Construction Material	Bowl	Metal

Modular Regulators – BANTAM Series

Port Sizes: 1/8, 1/4, 3/8 – Flow to 23 scfm



Port Type	Port Size	Model Number					
		Piston			Diaphragm		
		Regulated Pressure psig (bar)					
		0-50 (0-3.4)	0-100 (0-6.9)	0-125 (0-8.6)	0-50 (0-3.4)	0-100 (0-6.9)	0-125 (0-8.6)
Threaded	1/8 NPTF	5B01C0030	5B01C0010	5B01C0050	5B01C0040	5B01C0020	5B01C0060
	1/8 G	C5B01C0030	C5B01C0010	C5B01C0050	C5B01C0040	C5B01C0020	C5B01C0060
	1/4 NPTF	5B02C0030	5B02C0010	5B02C0050	5B02C0040	5B02C0020	5B02C0060
	1/4 G	C5B02C0030	C5B02C0010	C5B02C0050	C5B02C0040	C5B02C0020	C5B02C0060
Quick Connect TUBE Fittings	1/4	5B03C0030	5B03C0010	5B03C0050	5B03C0040	5B03C0020	5B03C0060
	3/8	5B04C0030	5B04C0010	5B04C0050	5B04C0040	5B04C0020	5B04C0060
	4mm	5B05C0030	5B05C0010	5B05C0050	5B05C0040	5B05C0020	5B05C0060
	6mm	5B06C0030	5B06C0010	5B06C0050	5B06C0040	5B06C0020	5B06C0060
	8mm	5B07C0030	5B07C0010	5B07C0050	5B07C0040	5B07C0020	5B07C0060
	10mm	5B08C0030	5B08C0010	5B08C0050	5B08C0040	5B08C0020	5B08C0060

Pressure Gauge included.

Port Size	Port Size	Dimensions inches (mm)				Weight lb (kg)		
		A	B	C	Depth*			
Threaded	No Port	1.7 (43)	2.6 (67)	0.5 (13)	1.8 (45)	0.21 (0.09)		
	1/8, 1/4 (NPT or G)	3.0 (76)	2.6 (67)	0.5 (13)	1.8 (45)	0.43 (0.19)		
Quick Connect TUBE Fittings	1/4	3.4 (86)	2.6 (67)	0.5 (13)	1.8 (45)	0.21 (0.09)		
	3/8	3.9 (99)	2.6 (67)	0.5 (13)	1.8 (45)	0.21 (0.09)		
	4 mm	3.4 (86)	2.6 (67)	0.5 (13)	1.8 (45)	0.41 (0.18)		
	6 mm	3.4 (86)	2.6 (67)	0.5 (13)	1.8 (45)	0.41 (0.18)		
	8 mm	3.1 (79)	2.6 (67)	0.5 (13)	1.8 (45)	0.41 (0.18)		
	10 mm	3.9 (99)	2.6 (67)	0.5 (13)	1.8 (45)	0.41 (0.18)		

* Less gauge.

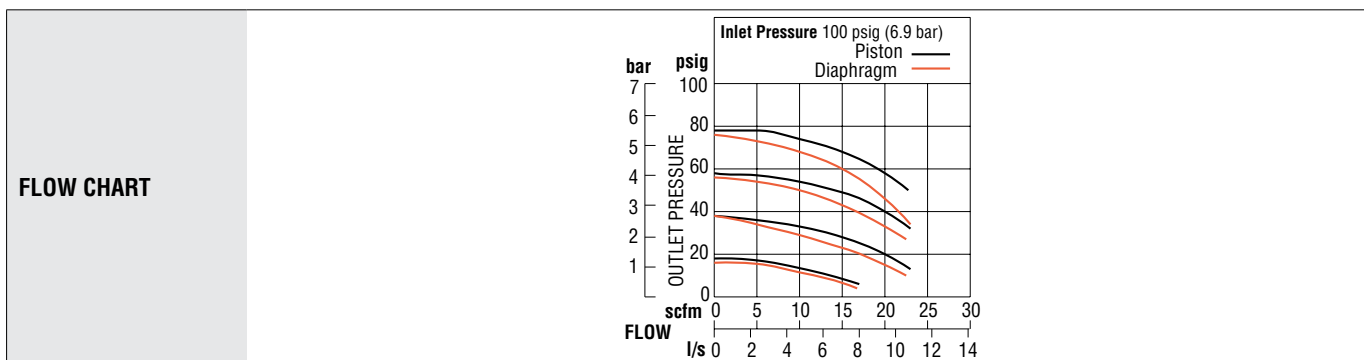

STANDARD SPECIFICATIONS

Construction Design	Piston or Diaphragm	Self-relieving For non-relieving option consult ROSS.
Temperature	Ambient	40° to 125°F (4° to 52°C)
	Media	
Fluid Media	Compressed air	
Operating Pressure	Inlet	Maximum 150 psig (10 bar)
	Outlet	Adjustable up to 100 psig (7 bar)
Pressure Gauge	0 to 160 psig (0 to 11 bar) 1/8 gauge ports front and rear	
Panel Mounting	1-3/16 inch (30 mm) hole required	
Construction Material	Body	Acetal
	Dome and Knob	Acetal
	Seals	Nitrile

In-line Regulators – MINIATURE Series



Port Sizes: 1/8, 1/4 – Flow to 40 scfm

Port Size	Port Thread	Model Number					
		Piston			Diaphragm		
		Regulated Pressure psig (bar)			Regulated Pressure psig (bar)		
		0-50 (0-3.4)	0-100 (0-6.9)	0-125 (0-8.6)	0-50 (0-3.4)	0-100 (0-6.9)	0-125 (0-8.6)
1/8	NPTF	5212C1004	5211C1004	5213C1004	5212C1005	5211C1005	5213C1005
	G	C5212C1004	C5211C1004	C5213C1004	C5212C1005	C5211C1005	C5213C1005
1/4	NPTF	5212C2004	5211C2004	5213C2004	5212C2005	5211C2005	5213C2005
	G	C5212C2004	C5211C2004	C5213C2004	C5212C2005	C5211C2005	C5213C2005

Pressure Gauge included.

Port Size	Dimensions inches (mm)				Weight* lb (kg)		ISO Symbol Regulator Self-Relieving
	A	B	C	Depth*			
1/8, 1/4	1.6 (41)	2.7 (68)	0.4 (10)	1.6 (41)	0.24 (0.11)		

* Less gauge.

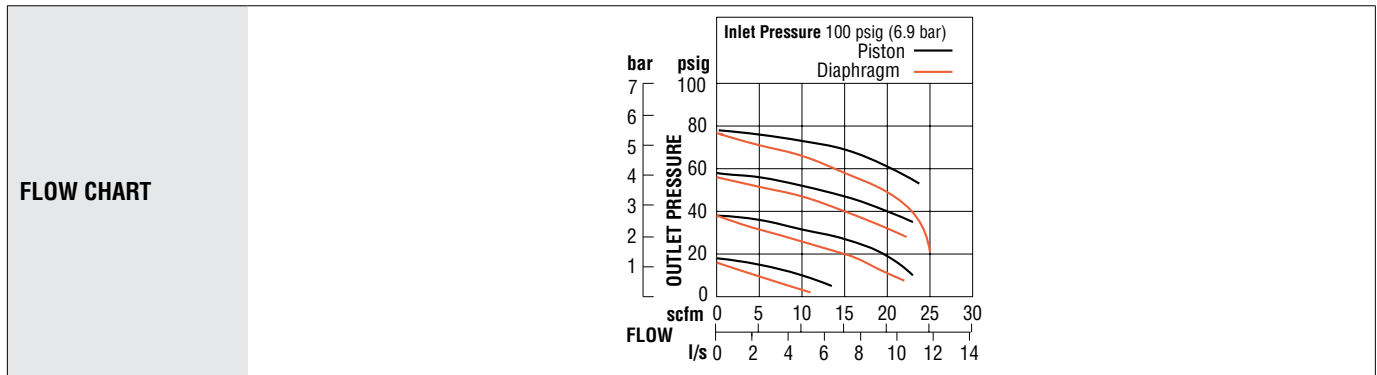

STANDARD SPECIFICATIONS

Construction Design	Piston or Diaphragm	Self-relieving For non-relieving option consult ROSS.
Temperature	Ambient	40° to 125°F (4° to 52°C)
	Media	
Fluid Media	Compressed air	
Operating Pressure	Inlet	Maximum 300 psig (21 bar)
	Outlet	Adjustable up to 100 psig (7 bar)
Pressure Gauge	0 to 160 psig (0 to 11 bar) 1/8 gauge ports front and rear	
Panel Mounting	1-3/16 inch (30 mm) hole required	
Construction Material	Body	Aluminum
	Dome and Knob	Acetal
	Seals	Nitrile

Modular Regulators – MID-SIZE Series

Port Sizes: 1/4, 3/8, 1/2 – Flow to 100 scfm



Port Size	Model Numbers					
	Pressure Range psig (bar)					
	0-50 (0-3.4)		0-100 (0-6.9)		0-150 (0-10.3)	
	NPTF Thread	G Thread	NPTF Thread	G Thread	NPTF Thread	G Thread
1/4	5212B2015	C5212B2015	5211B2015	C5211B2015	5213B2015	C5213B2015
3/8	5212B3015	C5212B3015	5211B3015	C5211B3015	5213B3015	C5213B3015
1/2	5212B4015	C5212B4015	5211B4015	C5211B4015	5213B4015	C5213B4015

Pressure Gauge included.

REGULATORS with REVERSE FLOW

Port Size	Regulated Pressure Range psig (bar)	Model Numbers			
		Pressure Adjustment			
		Knob		T-Handle	
		NPTF Thread	BSPP Thread	NPTF Thread	BSPP Thread
1/4	0-100 (0-6.9)	5X00B2035	C5X00B2035	5X00B2039	C5X00B2039
3/8	0-100 (0-6.9)	5X00B3024	C5X00B3024	5X00B3021	C5X00B3021
1/2	0-100 (0-6.9)	5X00B4023	C5X00B4023	5X00B4041	C5X00B4041

Pressure Gauge included.

Reverse-Flow Regulators provide regulated in-to-out pressure control, plus quick exhausting from out-to-in.

Used for downstream pressure regulation of weld guns and other applications requiring quick exhausting through the regulator.

Port Size	Dimensions inches (mm)				Weight* lb (kg)
	A	B	C	Depth*	
1/4, 3/8, 1/2	2.7 (68)	3.3 (83)	1.3 (33)	2.1 (52)	1.0 (0.46)

*Less gauge.

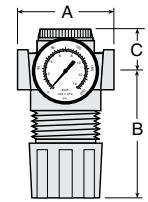

ISO Symbol Regulator Self-Relieving

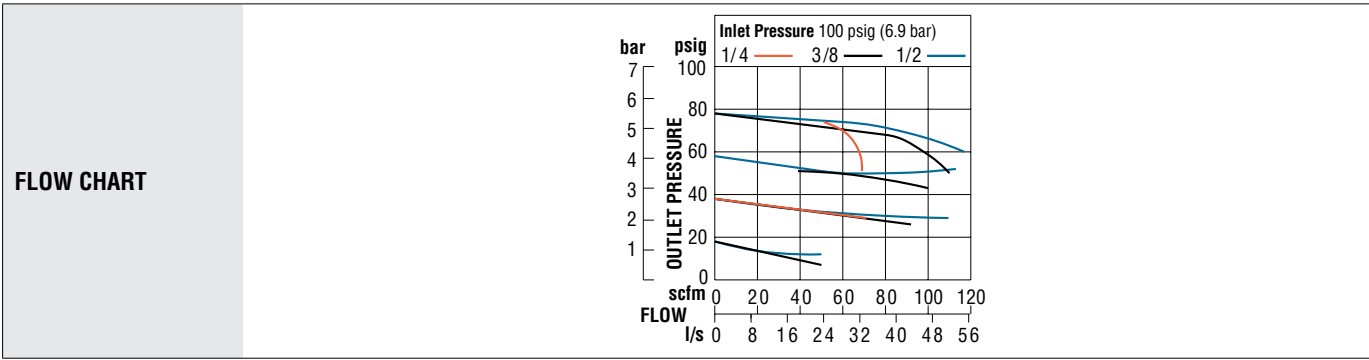
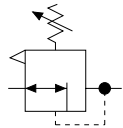

STANDARD SPECIFICATIONS

Construction Design	Piston or Diaphragm	Self-relieving For non-relieving option consult ROSS.
Temperature	Ambient	40° to 125°F (4° to 52°C)
	Media	
Fluid Media	Compressed air	
Operating Pressure	Inlet	Maximum 250 psig (17 bar)
	Outlet	Adjustable up to 150 psig (10 bar)
Pressure Gauge	0 to 200 psig (0 to 14 bar) 1/4 gauge ports front and rear	
Panel Mounting	1-9/16 inch (40 mm) hole required	
Construction Material	Body	Zinc
	Cap	Nylon
	Dome and Knob	Acetal
	Seals	Nitrile

Modular Regulators – MD3™ Series



Port Sizes: 1/4, 3/8, 1/2 – Flow to 120 scfm

Choose your options (in red) to configure your model number.

MD3 **52K** **A** **R** **C** **2** **2** **A**

Adjustment Type	
Knob	52K
Tee Handle	52T
Locking Knob	52L

Adjustment Range	
0-200 psig (0-13.8 bar)	A
0-150 psig (0-10.3 bar)	B
0-100 psig (0-6.9 bar)	C
0-50 psig (0-3.4 bar)	D

Port Size	
1/4 NPTF	2
3/8 NPTF	3
1/2 NPTF	4
1/4 G	B
3/8 G	C
1/2 G	D

Pressure Gauge	
Without Gauge	A
Gauge 0-200 psig (0-13.8 bar)	B
Gauge 0-60 psig (0-4.1 bar)	C
Without Gauge, with Panel Mount Nut	D
Gauge 0-200 psig (0-13.8 bar), with Panel Mount Nut	E
Gauge 0-60 psig (0-4.1 bar), with Panel Mount Nut	F

Flow Options	
Reverse Flow	R
Standard Flow	S

Port Size	Dimensions inches (mm)				Weight† lb (kg)
	A	B*	C**	Depth†	
1/4, 3/8, 1/2, 3/4	3.0 (76.2)	4.52 (114.9)	1.46 (37)	2.51 (63.8)	1.9 (0.86)

* Dome removal clearance: add 0.575 (14.6).
 ** Cap removal clearance: add 0.750 (19.1).
 † Less gauge.

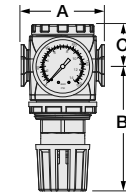

ISO Symbol Regulator Self-Relieving

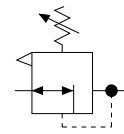

FLOW CHARTS

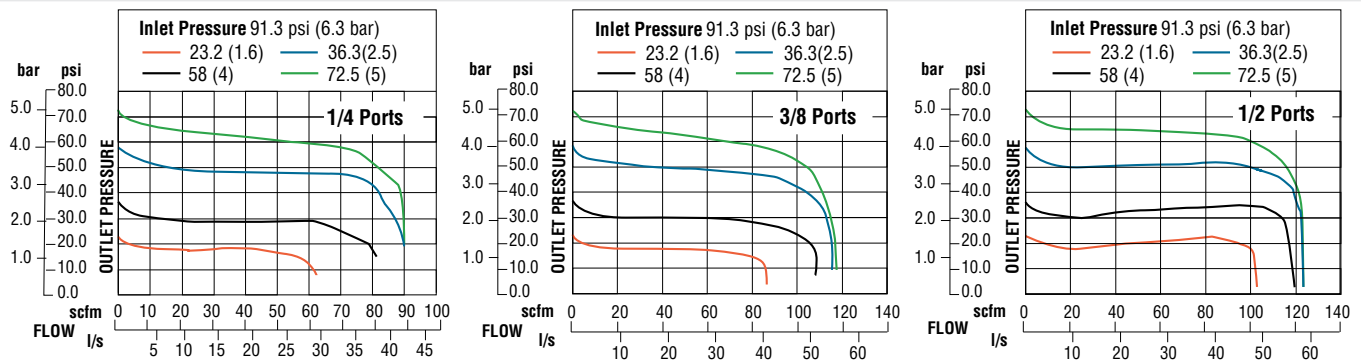

STANDARD SPECIFICATIONS

Construction Design	Piston or Diaphragm	Self-relieving For non-relieving option consult ROSS.
Temperature	Ambient	40° to 175°F (4° to 79°C)
	Media	
Fluid Media	Compressed air	
Operating Pressure	Inlet	Maximum 300 psig (21 bar)
	Outlet	Adjustable up to 200 psig (14 bar); optional adjusting springs.
Optional Pressure Adjustment	Locking Key	Removable
Pressure Gauge	0-200 psig (0-14 bar) or 0-60 psig (0-4 bar) 1/4-NPT gauge ports front and rear	
Panel Mounting	2-1/16 inch (52 mm) hole required	
Construction Material	Body	Zinc
	Dome	Nylon
	Knob	Acetal
	Seals	Nitrile
	Valve	Brass
	Valve Cap	Nylon

Modular Regulators – FULL-SIZE Series

Port Sizes: 1/4, 3/8, 1/2, 3/4 – Flow to 155 scfm



Port Size	Model Number					
	Pressure Range psig (bar)					
	0-50 (0-3.4)		0-125 (0-8.6)		0-175 (0-12.1)	
	NPTF Thread	G Thread	NPTF Thread	G Thread	NPTF Thread	G Thread
1/4	5212B2017	C5212B2017	5211B2017	C5211B2017	5213B2017	C5213B2017
3/8	5212B3017	C5212B3017	5211B3017	C5211B3017	5213B3017	C5213B3017
1/2	5212B4017	C5212B4017	5211B4017	C5211B4017	5213B4017	C5213B4017
3/4	5212B5027	C5212B5027	5211B5027	C5211B5027	5213B5027	C5213B5027

Pressure Gauge included.

REGULATORS with REVERSE FLOW

Port Size	Model Number			
	Pressure Adjustment 0-125 (0-8.6)			
	Knob		T-Handle	
	NPT Thread	G Thread	NPT Thread	G Thread
1/4	5X00B2010	C5X00B2010	–	–
3/8	5X00B3004	C5X00B3004	5X00B3012	C5X00B3012
1/2	5X00B4004	C5X00B4004	5X00B4047	C5X00B4047
3/4	5X00B5034	C5X00B5034	5X00B5044	C5X00B5044

Pressure Gauge included.

Port Size	Dimensions inches (mm)				Weight† lb (kg)
	A	B**	C***	Depth†	
1/4, 3/8, 1/2, 3/4	3.5 (89)	5.8 (146)	1.3 (33)	2.8 (71)	2.06 (0.92)

** Dome removal clearance: add 0.63 (16).
*** Cap removal clearance: add 0.5 (13).

† Less gauge.

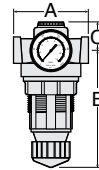

ISO Symbol Regulator
Self-Relieving

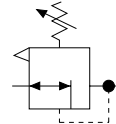

FLOW CHARTS

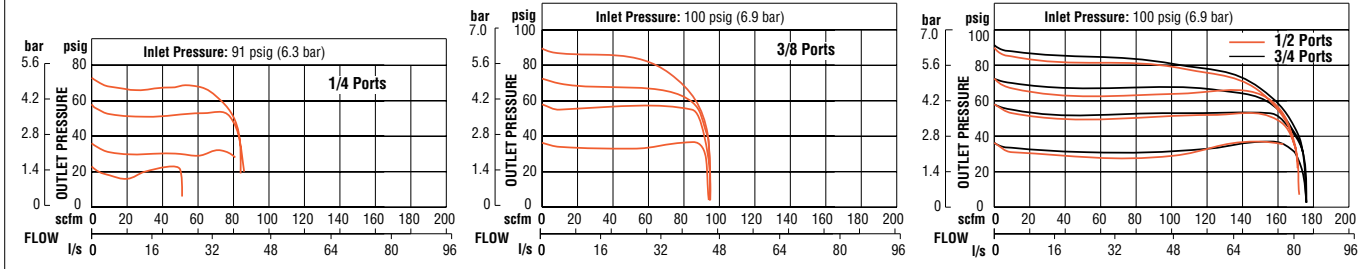

STANDARD SPECIFICATIONS

Construction Design	Diaphragm	Self-relieving. For non-relieving option consult ROSS.
Temperature	Ambient	40° to 175°F (4° to 79°C)
	Media	
Fluid Media	Compressed air	
Operating Pressure	Inlet	Maximum 300 psig (21 bar)
	Outlet	Adjustable up to 175 psig (12 bar); optional adjusting springs.
Optional Pressure Adjustment	Locking Key	Removable
Pressure Gauge	0-200 psig (0-14 bar); 1/4-NPT gauge ports front and rear	
Panel Mounting	2-1/16 inch (52 mm) hole required	
Construction Material	Body	Zinc
	Dome	Nylon; aluminum with optional 0 to 175 psig (0 to 12 bar) spring
	Knob	Acetal
	Seals	Nitrile
	Valve	Brass
	Valve Cap	Nylon

Modular Regulators – MD4™ Series



Port Sizes: 3/8, 1/2, 3/4 – Flow to 220 scfm

Choose your options (in red) to configure your model number.

MD4 **52K** **A** **R** **B** **5** **2** **B**

Adjustment Type	
Knob	52K
Tee Handle	52T

Adjustment Range	
0-175 psig (0-12.1 bar)	A
0-125 psig (0-8.6 bar)	B
0-50 psig (0-3.4 bar)	C
0-20 psig (0-1.4 bar)	D

Flow Options	
Reverse Flow	R
Standard Flow	S

Port Size	
3/8 NPTF	3
1/2 NPTF	4
3/4 NPTF	5
3/8 G	C
1/2 G	D
3/4 G	E

Pressure Gauge	
Without Gauge	A
Gauge 0-200 psig (0-13.8 bar)	B
Gauge 0-60 psig (0-4.1 bar)	C
Without Gauge, with Panel Mount Nut	D
Gauge 0-200 psig (0-13.8 bar), with Panel Mount Nut	E
Gauge 0-60 psig (0-4.1 bar), with Panel Mount Nut	F

Cap Color	
Black	2
Yellow	Y

Port Size	Dimensions inches (mm)				Weight † lb (kg)
	A	B*	C**	Depth †	
3/8, 1/2, 3/4	3.5 (87)	5.6 (142)	1.6 (40)	2.9 (73)	2.56 (1.16)

* Dome removal clearance: add 0.625 (16).

** Cap removal clearance: add 0.50 (13).

† Dimensions reflect less gauge.

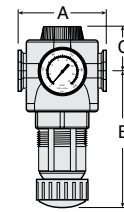

ISO Symbol Regulator
Self-Relieving

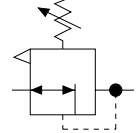

FLOW CHARTS

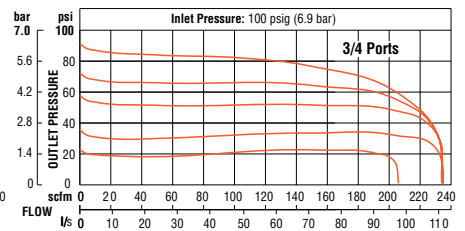
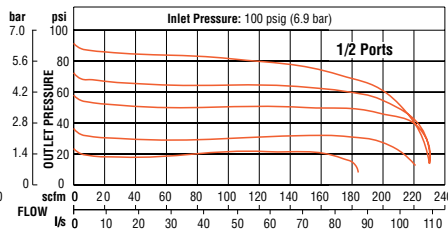
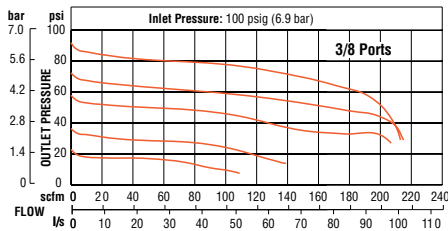

STANDARD SPECIFICATIONS

Construction Design	Piston or Diaphragm	Self-relieving For non-relieving option consult ROSS.
Temperature	Ambient	40° to 175°F (4° to 79°C)
	Media	
Fluid Media	Compressed air	
Operating Pressure	Inlet	Maximum 300 psig (21 bar)
	Outlet	Adjustable up to 175 psig (12 bar); optional adjusting springs.
Optional Pressure Adjustment	Locking Key	Removable
Pressure Gauge	0-200 psig (0-14 bar) or 0-60 psig (0-4 bar) 1/4-NPT gauge ports front and rear	
Panel Mounting	2-1/16 inch (52 mm) hole required	
Construction Material	Body	Zinc
	Dome	Nylon; aluminum with optional 0 to 175 psig (0 to 12 bar) spring
	Knob	Acetal
	Seals	Nitrile
	Valve	Brass
	Valve Cap	Nylon

In-line Regulators – HIGH-CAPACITY Series

Port Sizes: 3/4, 1, 1-1/4, 1-1/2 – Flow to 800 scfm



Port Size	Model Number			
	Pressure Range psig (bar)			
	0-50 (0-3.4)		0-100 (0-6.9)	
	NPTF Thread	G Thread	NPTF Thread	G Thread
3/4	5212D5017	C5212D5017	5211D5017	C5211D5017
1	5212D6017	C5212D6017	5211D6017	C5211D6017
1-1/4	5212C7017	C5212C7017	5211C7017	C5211C7017
1-1/2	5212C8017	C5212C8017	5211C8017	C5211C8017

Pressure Gauge included.

REGULATORS with REVERSE FLOW

Port Size	Pressure Range psig (bar)	Model Number			
		Pressure Adjustment			
		Knob		T-Handle	
		NPTF Thread	G Thread	NPTF Thread	G Thread
3/4	0-100 (0-6.9)	5X00B5049	C5X00B5049	5X00B5050	C5X00B5050
1	0-100 (0-6.9)	5X00D6003	C5X00D6003	5X00B6038	C5X00B6038
1-1/4	0-100 (0-6.9)	5X00C7003	C5X00C7003	5X00B7016	C5X00B7016
1-1/2	0-100 (0-6.9)	5X00C8001	C5X00C8001	5X00B8024	C5X00B8024

Pressure Gauge included.

Port Size	Dimensions inches (mm)				Weight † lb (kg)
	A	B**	C***	Depth †	
3/4, 1	4.4 (111)	6.1 (154)	2.4 (62)	2.8 (71)	2.19 (0.99)
1-1/4, 1-1/2	4.9 (124)	6.4 (162)	2.1 (54)	2.8 (71)	2.50 (1.14)

** Dome removal clearance: add 0.63 (16).
 *** Cap removal clearance: add 0.65 (16.5).
 † Dimensions reflect less gauge.

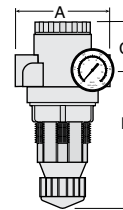

ISO Symbol Regulator
Self-Relieving

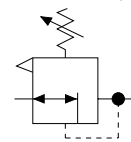

FLOW CHARTS

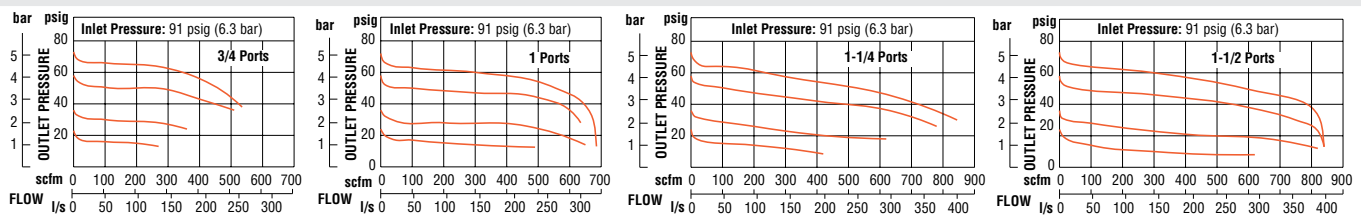

STANDARD SPECIFICATIONS

Construction Design	Piston	Self-relieving
Temperature	Ambient	40° to 175°F (4° to 79°C)
	Media	
Fluid Media	Compressed air	
Operating Pressure	Inlet	Maximum 300 psig (21 bar)
	Outlet	Adjustable up to 100 psig (7 bar)
Optional Pressure Adjustment	Locking Key	Removable
Pressure Gauge	0-200 psig (0-14 bar); 1/4-NPT gauge ports front and rear	
Panel Mounting	2-1/16 inch (52 mm) hole required	
Construction Material	Body	Aluminum
	Dome	Nylon; aluminum with optional 0 to 150 psig (0 to 10 bar) spring
	Knob	Acetal
	Seals	Nitrile
	Valve	Brass
	Valve Cap	Nylon

In-line High-Pressure Regulators – HIGH-PRESSURE Series



Port Sizes: 1/8, 1/4, 3/8 – Flow to 70 scfm

Port Size	Model Number			
	Piston Type			
	Relieving		Non-Relieving	
	NPTF Thread	G Thread	NPTF Thread	G Thread
1/8	5215B1004	C5215B1004	5X00B1025	C5X00B1025
1/4	5215B2004	C5215B2004	5X00B2076	C5X00B2076
3/8	5215B3004	C5215B3004	5X00B3052	C5X00B3052

Pressure Gauge included.

Port Size	Dimensions inches (mm)				Weight** lb (kg)
	A	B	C	Depth**	
1/8, 1/4	1.9 (47)	7.3 (186) max	0.4 (10)	1.9 (47)	1.15 (0.53)
3/8	2.1 (54)	7.4 (188) max	0.5 (13)	2.1 (54)	1.30 (0.59)

** Less gauge.

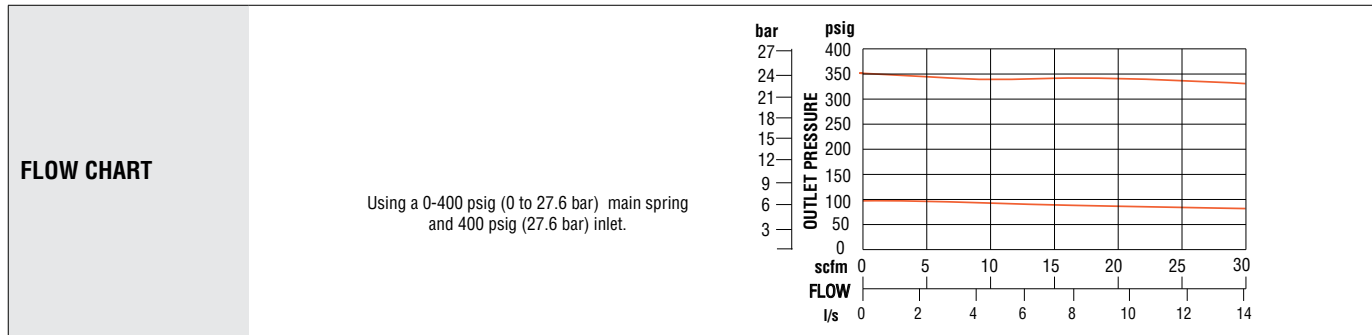
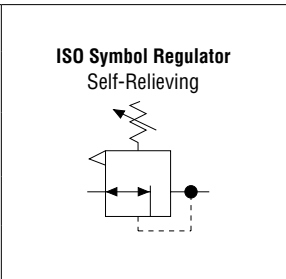
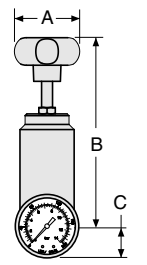

STANDARD SPECIFICATIONS

Construction Design	Piston	Self-relieving, Non-relieving
Temperature	Ambient	40° to 175°F (4° to 79°C)
	Media	
Fluid Media	Compressed air	
Operating Pressure	Inlet	Maximum 400 psig (28 bar)
	Outlet	Adjustable up to 390 psig (27 bar)
Pressure Gauge	0-600 psig (0-40 bar)	
Maximum Flow Rate	70 scfm (33.0 l/s) @400 psi (28 bar)	
Construction Material	Body	Aluminum
	Dome	Aluminum
	Knob	Nylon
	Seals	Fluoroelastomer
	Valve	Brass
	Valve Cap	Nylon

In-line Precision Regulators – MINIATURE Series

Port Sizes: 1/8 & 1/4 – Flow to 4 scfm

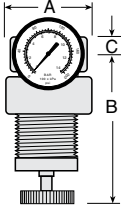
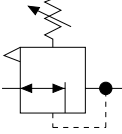

Port Size	Regulated Pressure Range# psig (bar)	Model Number	
		NPTF Thread	G Thread
1/8	0-50 (0-3.4)	5212C1006	C5212C1006
1/4	0-50 (0-3.4)	5212C2006	C5212C2006
# For 0-10 psig (0-0.7 bar), 0-20 psig (0-1.4 bar), and 0-60 psig (0-4.1 bar) ranges, consult ROSS.			
Pressure Gauge included.			

Port Size	Dimensions inches (mm)				Weight** lb (kg)		
	A	B	C	Depth**			
1/8, 1/4	1.8 (44)	3.4 (86)	0.4 (10)	1.8 (44)	0.38 (0.16)		
** Less gauge.							

Precision Regulators have a small valve seat and a large diaphragm area, a combination that allows greater precision, sensitivity, adjustment resolution, and less variation in regulated pressure.

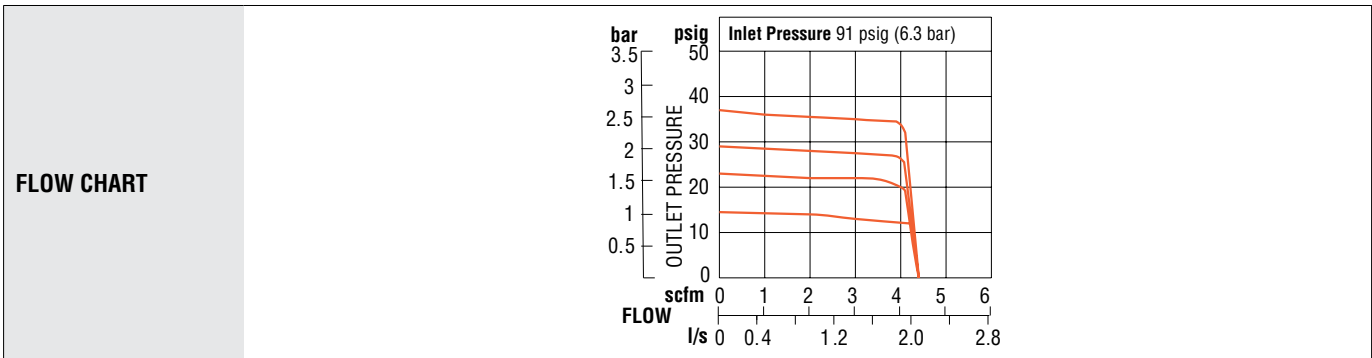

STANDARD SPECIFICATIONS

Construction Design	Diaphragm	Self-relieving
Temperature	Ambient	40° to 125°F (4° to 52°C)
	Media	
Fluid Media	Compressed air	
Operating Pressure	Inlet	Maximum 300 psig (21 bar)
	Outlet	Adjustable up to 100 psig (7 bar)
Pressure Gauge	0-160 psig (0-11 bar); 1/8-NPT gauge ports front and rear	
Panel Mounting	1-3/16 inch (30 mm) hole required	
Construction Material	Body	Aluminum
	Dome	Acetal
	Knob	Acetal
	Seals	Nitrile

Modular Precision Regulators – FULL-SIZE Series



Port Sizes: 1/4, 3/8, 1/2, 3/4 – Flow to 155 scfm



Port Size	Model Number			
	Internally Piloted Regulator			
	Pressure Range psig (bar)			
	15-200 (1-13.8)		15-250 (1-17.2)	
	NPTF Thread	G Thread	NPTF Thread	G Thread
1/4	5213C2018	C5213C2018	5214C2018	C5214C2018
3/8	5213C3018	C5213C3018	5214C3018	C5214C3018
1/2	5213C4018	C5213C4018	5214C4018	C5214C4018
3/4	5213C5018	C5213C5018	5214C5018	C5214C5018

Pressure Gauge included.

Port Size	Dimensions inches (mm)				Weight† lb (kg)
	A	B**	C***	Depth†	
1/4, 3/8, 1/2, 3/4	3.5 (89)	4.2 (106)	1.3 (33)	2.8 (71)	2.06 (0.92)

** Dome removal clearance: add 0.63 (16).
 *** Cap removal clearance: add 0.5 (13).
 † Less gauge.

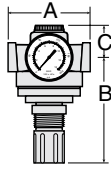

**ISO Symbol Regulator
Self-Relieving**

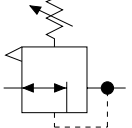

Precision internal Pilot Regulators provide improved torque control for pneumatic tools; diaphragm type. Pressure settings held within 3 psig (0.2 bar).

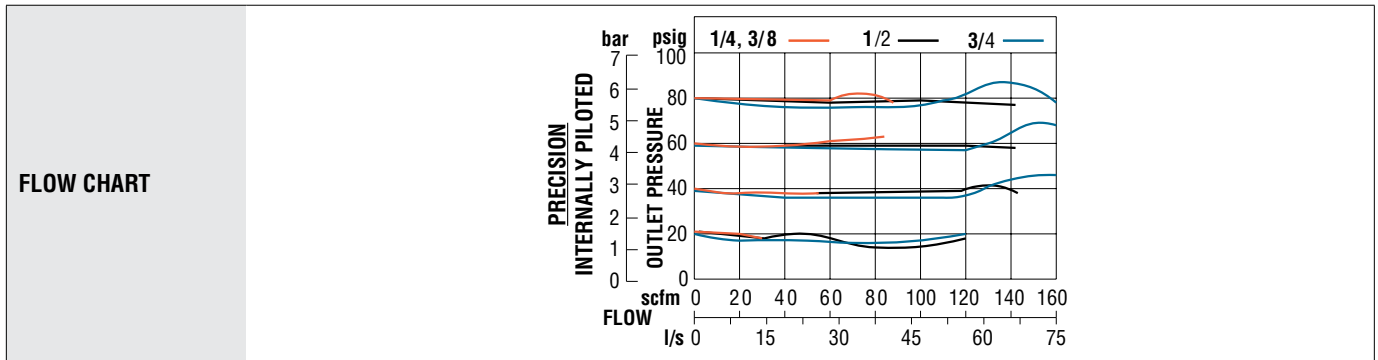

STANDARD SPECIFICATIONS

Construction Design	Diaphragm	Self-relieving
Temperature	Ambient	40° to 125°F (4° to 52°C)
	Media	
Fluid Media	Compressed air	
Operating Pressure	Inlet	Maximum 300 psig (21 bar)
	Outlet	Adjustable 15 to 250 psig (1 to 17 bar)
Pressure Gauge	0 to 200 psig (0 to 14 bar); 1/4 NPT gauge ports front and rear	
Panel Mounting	2-1/16 inch (52 mm) hole required	
Construction Material	Body	Zinc
	Dome	Nylon; Aluminum with optional 0 to 175 psig (0 to 12 bar) spring
	Knob	Acetal
	Seals	Nitrile
	Valve	Brass
	Valve Cap	Nylon

Modular Precision Regulators – MD4™ Series

Port Sizes: 3/8, 1/2, 3/4 – Flow to 170 scfm

Choose your options (in red) to configure your model number.

MD4 **52K** **E** **C** **5** **2** **B**

Adjustment Range	
15-200 psig (1.0-13.8 bar)	E
15-250 psig (1.0-17.2bar)	F
15-100 psig (1.0-6.9 bar)	G

Port Size	
3/8 NPTF	3
1/2 NPTF	4
3/4 NPTF	5
3/8 G	C
1/2 G	D
3/4 G	E

Pressure Gauge	
Without Gauge	A
Gauge 0-200 psig (0-13.8 bar)	B
Without Gauge, with Panel Mount Nut	D
Gauge 0-200 psig (0-13.8 bar), with Panel Mount Nut	E

Cap Color	
Black	2
Yellow	Y



Port Size	Dimensions inches (mm)				Weight † lb (kg)
	A	B	C	Depth †	
3/8, 1/2, 3/4	3.5 (87)	4.8 (122)	1.6 (40)	2.9 (73)	2.3 (1.0)

† Dimensions reflect less gauge.

ISO Symbol Regulator Self-Relieving

FLOW CHARTS

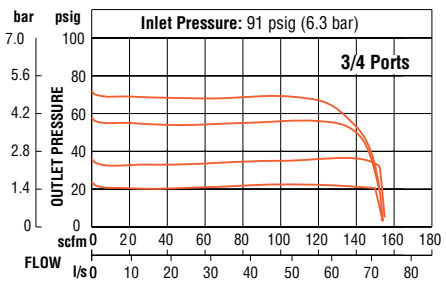
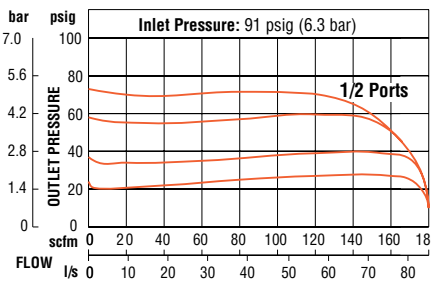
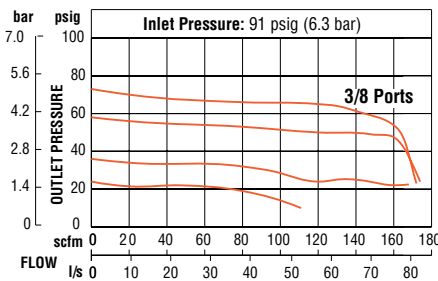

Precision Regulators: Provide improved torque control for pneumatic tools. Pressure settings held within 3 psig (0.2 bar).

STANDARD SPECIFICATIONS

Construction Design	Diaphragm	Self-relieving
Temperature	Ambient	40° to 125°F (4° to 52°C)
	Media	
Fluid Media	Compressed air	
Operating Pressure	Inlet	Maximum 250 psig (17 bar)
	Outlet	Adjustable 15 to 250 psig (1 to 17 bar)
Pressure Gauge	0 to 200 psig (0 to 14 bar); 1/4 NPT gauge ports front and rear	
Panel Mounting	2-1/16 inch (52 mm) hole required	
Construction Material	Body	Zinc
	Bonnet and Knob	Acetal
	Dome	Zinc
	Seals	Nitrile
	Valve	Brass

In-line Precision Regulators – HIGH-CAPACITY Series



Port Sizes: 3/4, 1, 1-1/4, 1-1/2 – Flow to 800 scfm



Port Size	Model Number			
	Pressure Range psig (bar)			
	15-200 (1-13.8)		15-250 (1-17.2)	
	NPTF Thread	G Thread	NPTF Thread	G Thread
3/4	5213D5017	C5213D5017	5214D5017	C5214D5017
1	5213D6017	C5213D6017	5214D6017	C5214D6017
1-1/4	5213D7017	C5213D7017	5214D7017	C5214D7017
1-1/2	5213D8017	C5213D8017	5214D8017	C5214D8017

Pressure Gauge included.

Port Size	Dimensions inches (mm)				Weight † lb (kg)		ISO Symbol Regulator Self-Relieving
	A	B	C	Depth †			
3/4, 1	4.4 (111)	4.6 (112)	2.4 (62)	2.8 (71)	2.0 (0.91)		
1-1/4, 1-1/2	4.9 (124)	4.9 (125)	2.1 (54)	2.8 (71)	2.38 (1.08)		

† Dimensions reflect less gauge.

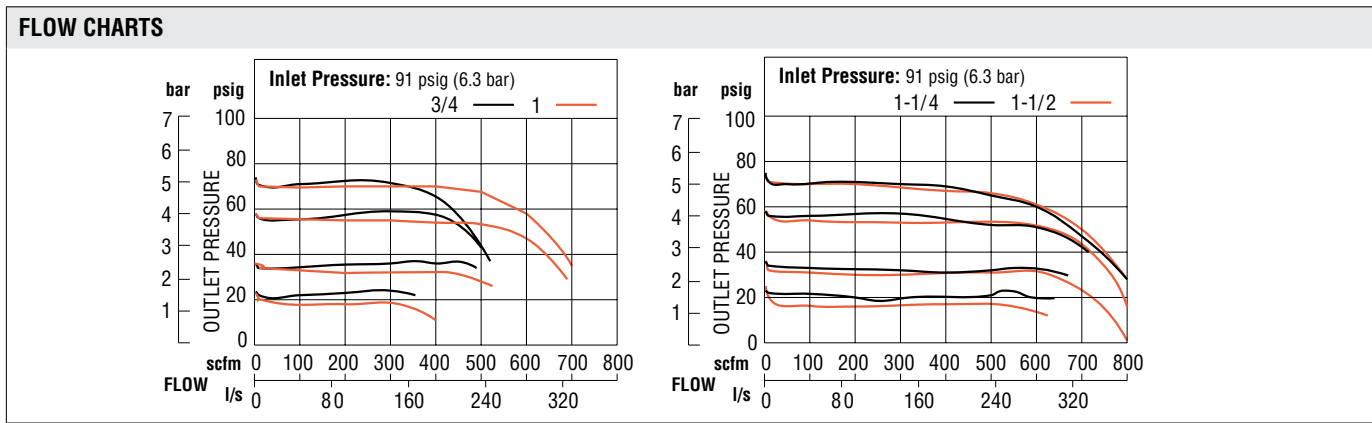

Precision Regulators: Provide improved torque control for pneumatic tools. Pressure settings held within 3 psig (0.2 bar).

STANDARD SPECIFICATIONS		
Construction Design	Diaphragm	Self-relieving
Temperature	Ambient	40° to 175°F (4° to 79°C)
	Media	
Fluid Media	Compressed air	
Operating Pressure	Inlet	Maximum 300 psig (21 bar)
	Outlet	Adjustable 15 to 250 psig (1 to 17 bar)
Pressure Gauge	0 to 200 psig (0 to 14 bar); 1/4 NPT gauge ports front and rear	
Panel Mounting	1-3/16 (30 mm) hole required	
Construction Material	Body	Aluminum
	Bonnet and Knob	Acetal
	Dome	Zinc
	Seals	Nitrile
	Valve	Brass
	Valve Cap	Nylon

Modular Remote Pilot Regulators – FULL-SIZE Series

Port Sizes: 1/4, 3/8, 1/2, 3/4 – Flow to 155 scfm



Port Size	Model Number	
	Pressure Range psig (bar) 0-200 (0-13.8)	
	NPTF Thread	G Thread
1/4	5211C2007	C5211C2007
3/8	5211C3007	C5211C3007
1/2	5211C4007	C5211C4007
3/4	5211C5007	C5211C5007

Pressure Gauge included.

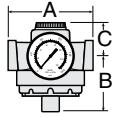
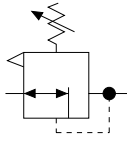
Port Size	Dimensions inches (mm)				Weight† lb (kg)		ISO Symbol Regulator Self-Relieving 
	A	B**	C***	Depth†			
1/4, 3/8, 1/2, 3/4	3.5 (89)	2.4 (62)	1.3 (33)	2.8 (71)	2.06 (0.92)		

** Dome removal clearance: add 0.63 (16).
 *** Cap removal clearance: add 0.5 (13).
 † Less gauge.

Remote Pilot Regulators use any small regulator to provide remote adjustment and to ensure accurate pressure control.

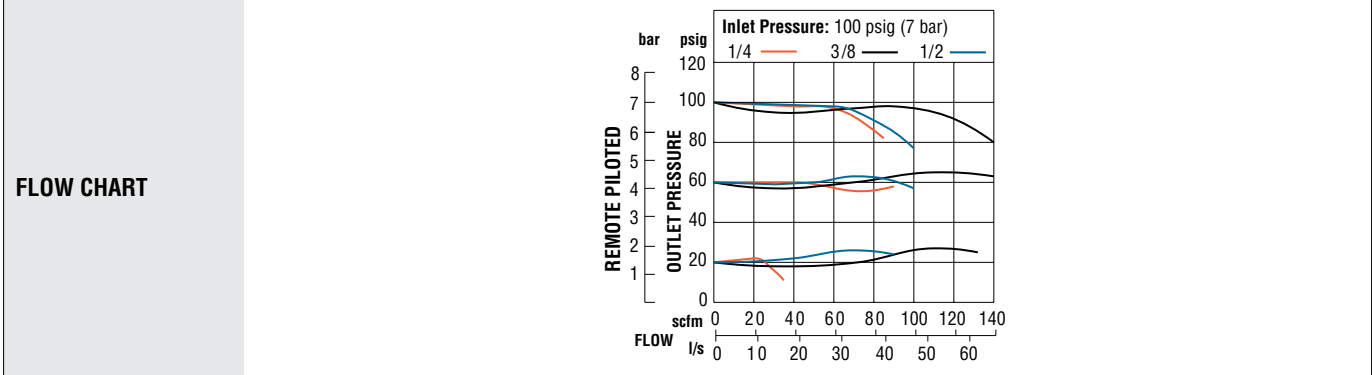

STANDARD SPECIFICATIONS		
Construction Design	Diaphragm	Self-relieving
Temperature	Ambient	40° to 125°F (4° to 52°C)
	Media	
Fluid Media	Compressed air	
Operating Pressure	Inlet	Maximum 300 psig (21 bar)
	Outlet	Adjustable 15 to 250 psig (1 to 17 bar)
Pressure Gauge	0 to 200 psig (0 to 14 bar); 1/4 NPT gauge ports front and rear	
Panel Mounting	2-1/16 inch (52 mm) hole required	
Construction Material	Body	Zinc
	Dome	Zinc
	Knob	Acetal
	Seals	Nitrile
	Valve	Brass
	Valve Cap	Nylon

Modular Remote High-Relief Pilot Regulators – FULL-SIZE Series



Port Sizes: 1/4, 3/8, 1/2, 3/4 – Flow to 150 scfm



Port Size	Model Number	
	NPTF Thread	G Thread
1/4	5X00B2037	C5X00B2037
3/8	5X00B3025	C5X00B3025
1/2	5X00B4040	C5X00B4040
3/4	5X00B5035	C5X00B5035

Pressure Gauge included.

Port Size	Dimensions inches (mm)				Weight † lb (kg)
	A	B	C	Depth †	
1/4, 3/8, 1/2, 3/4	3.5 (87)	2.4 (62)	1.3 (33)	2.8 (71)	2.06 (0.92)

† Dimensions reflect less gauge.

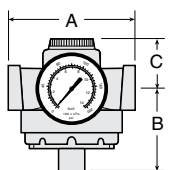

ISO Symbol Regulator

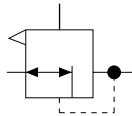

FLOW CHARTS

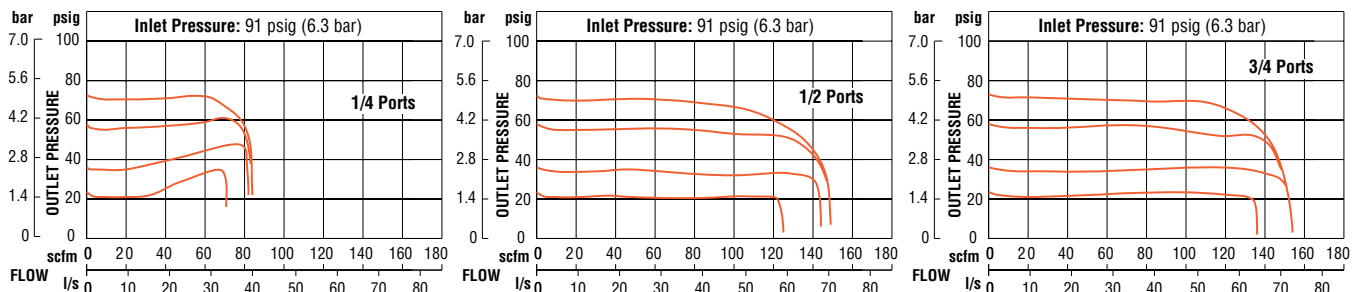

STANDARD SPECIFICATIONS

Construction Design	Diaphragm	Self-relieving
Temperature	Ambient	40° to 175°F (4° to 79°C)
	Media	
Fluid Media	Compressed air	
Operating Pressure	Inlet	Maximum 300 psig (21 bar)
	Outlet	Adjustable 15 to 200 psig (1 to 14 bar)
Pressure Gauge	0 to 200 psig (0 to 14 bar); 1/4 NPT gauge ports front and rear	
Pilot Ports	1/4 NPTF	
Panel Mounting	2-1/16 inch (52 mm) hole required	
Construction Material	Body	Zinc
	Dome	Zinc
	Seals	Nitrile Fluoroelastomer seals optional, consult ROSS
	Valve	Brass
	Valve Cap	Nylon

In-line Premium High-Relief Remote Pilot Regulators – FULL-SIZE Series

Port Sizes: 1/4, 3/8, 1/2 – Flow to 150 scfm



Port Size	Model Number	
	NPTF Thread	G Thread
1/4	5216A2007	C5216A2007
3/8	5216A3007	C5216A3007
1/2	5216A4007	C5216A4007

Pressure Gauge included.

Port Size	Dimensions inches (mm)				Weight† lb (kg)
	A	B**	C***	Depth†	
1/4, 3/8, 1/2	4.18 (106)	1.54 (39.1)	3.52 (89.3)	4.18 (106)	4.84 (2.2)

** Dome removal clearance: add 0.63 (16).
 *** Cap removal clearance: add 0.5 (13).
 † Less gauge.

ISO Symbol
 With Conventional Pilot Regulator
 Self-Relieving

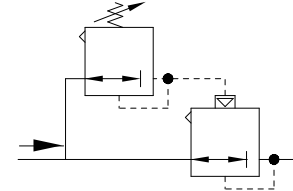

FLOW CHARTS

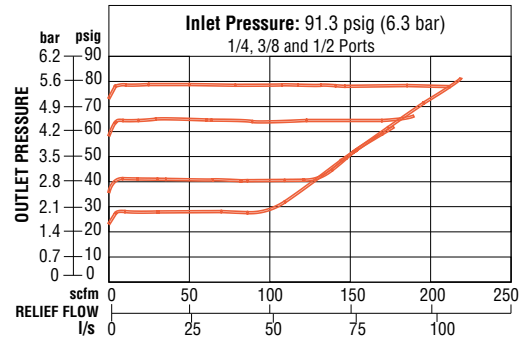
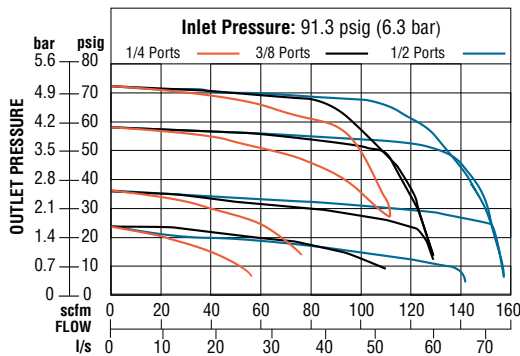

STANDARD SPECIFICATIONS

Construction Design	Diaphragm	Self-relieving
Temperature	Ambient	0° to 158°F (-18° to 70°C)
	Media	
Fluid Media	Compressed air	
Operating Pressure	Inlet	Maximum 400 psig (28 bar)
	Outlet	Adjustable up to 250 psig (17 bar)
Pressure Gauge	0 to 200 psig (0 to 14 bar) standard, 1/4-NPTF (1/4 BSPP) gauge ports front and rear; 0 to 600 psig (0 to 40 bar) optional	
Construction Material	Body	Zinc
	Dome	Zinc
	Seals	Nitrile
	Valve	Brass
	Valve Cap	Glass filled Nylon

Modular Remote Pilot Regulators – MD4™ Series



Port Sizes: 3/8, 1/2, 3/4 – Flow to 190 scfm

Choose your options (in red) to configure your model number.

MD4 **52K** **1** **B** **5** **2** **B**

Relief Options	
Relieving	1
Non-relieving	2

Pressure Gauge	
Without Gauge	A
Gauge 0-200 psig (0-13.8 bar)	B

Port Size	
3/8 NPTF	3
1/2 NPTF	4
3/4 NPTF	5
3/8 G	C
1/2 G	D
3/4 G	E

Cap Color	
Black	2
Yellow	Y



Port Size	Dimensions inches (mm)				Weight † lb (kg)		
	A	B	C	Depth †			
1/4, 3/8, 1/2, 3/4	3.5 (87)	2.4 (62)	1.6 (41)	2.9 (73)	2.2 (1.0)		

† Dimensions reflect less gauge.

FLOW CHARTS

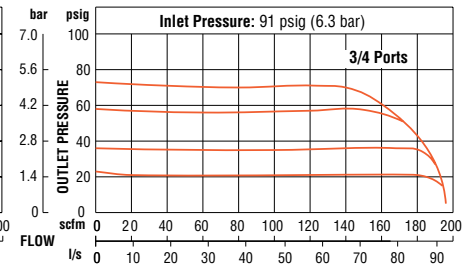
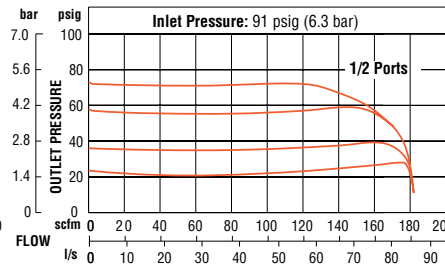
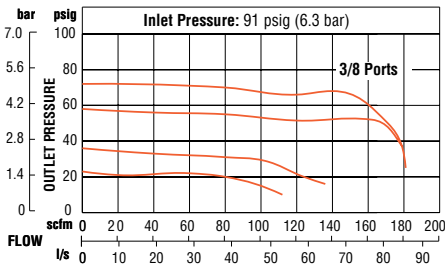

STANDARD SPECIFICATIONS

Construction Design	Diaphragm	Self-relieving
Temperature	Ambient	40° to 175°F (4° to 79°C)
	Media	
Fluid Media	Compressed air	
Operating Pressure	Inlet	Maximum 300 psig (21 bar)
	Outlet	Adjustable 0 to 250 psig (0 to 17 bar)
Pressure Gauge	0 to 200 psig (0 to 14 bar); 1/4 NPT gauge ports front and rear	
Construction Material	Body	Zinc
	Dome	Zinc
	Seals	Nitrile
	Valve	Brass
	Valve Cap	Nylon

In-line Remote Pilot Regulators – HIGH-CAPACITY Series

Port Sizes: 3/4, 1, 1-1/4, 1-1/2 – Flow to 740 scfm

Port Size	Model Number	
	NPTF Thread	G Thread
3/4	5211D5006	C5211D5006
1	5211D6007	C5211D6007
1-1/4	5211D7007	C5211D7007
1-1/2	5211D8007	C5211D8007

Pressure Gauge included.



Port Size	Dimensions inches (mm)				Weight† lb (kg)
	A	B*	C**	Depth†	
3/4, 1	4.4 (111)	2.9 (74)	2.4 (62)	2.8 (71)	1.88 (0.85)
1-1/4, 1-1/2	4.9 (124)	3.2 (81)	2.1 (54)	2.8 (71)	2.25 (1.02)

† Less gauge.

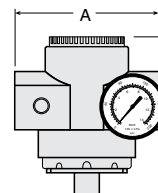

ISO Symbol Regulator

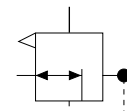

FLOW CHART

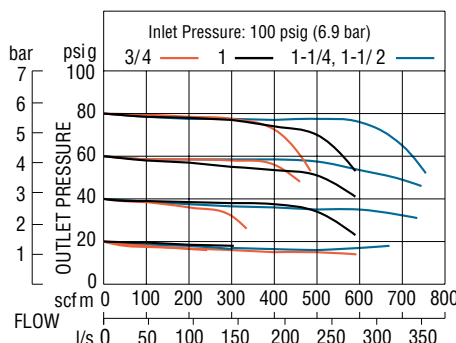

STANDARD SPECIFICATIONS

Construction Design	Diaphragm	Self-relieving
Temperature	Ambient	40° to 175°F (4° to 79°C)
	Media	
Fluid Media	Compressed air	
Operating Pressure	Inlet	Maximum 300 psig (21 bar)
	Outlet	Adjustable 0 to 200 psig (0 to 14 bar) <i>NOTE: Outlet pressure depends on the adjustment of the pilot regulator</i>
Pilot Ports	1/4-NPTF	
Pressure Gauge	0 to 200 psig (0 to 14 bar) standard; 1/4 NPT gauge ports front and rear	
Construction Material	Body	Aluminum
	Dome	Zinc
	Seals	Nitrile
	Valve	Brass
	Valve Cap	Nylon

In-line High-Relief Remote Pilot Regulators – HIGH-CAPACITY Series



Port Sizes: 3/4, 1, 1-1/4, 1-1/2 – Flow to 700 scfm

Port Size	Model Number	
	NPTF Thread	G Thread
3/4	5X00B5046	C5X00B5046
1	5X00B6039	C5X00B6039
1-1/4	5X00B7021	C5X00B7021
1-1/2	5X00B8049	C5X00B8049

Pressure Gauge included.



Port Size	Dimensions inches (mm)				Weight† lb (kg)		
	A	B**	C***	Depth†			
3/4, 1	4.4 (111)	2.9 (74)	2.4 (62)	2.8 (71)	1.88 (0.85)		
1-1/4, 1-1/2	4.9 (124)	3.2 (81)	2.1 (54)	2.8 (71)	2.25 (1.02)		

** Dome removal clearance: add 0.63 (16).
 *** Cap removal clearance: add 0.5 (13).
 † Less gauge.

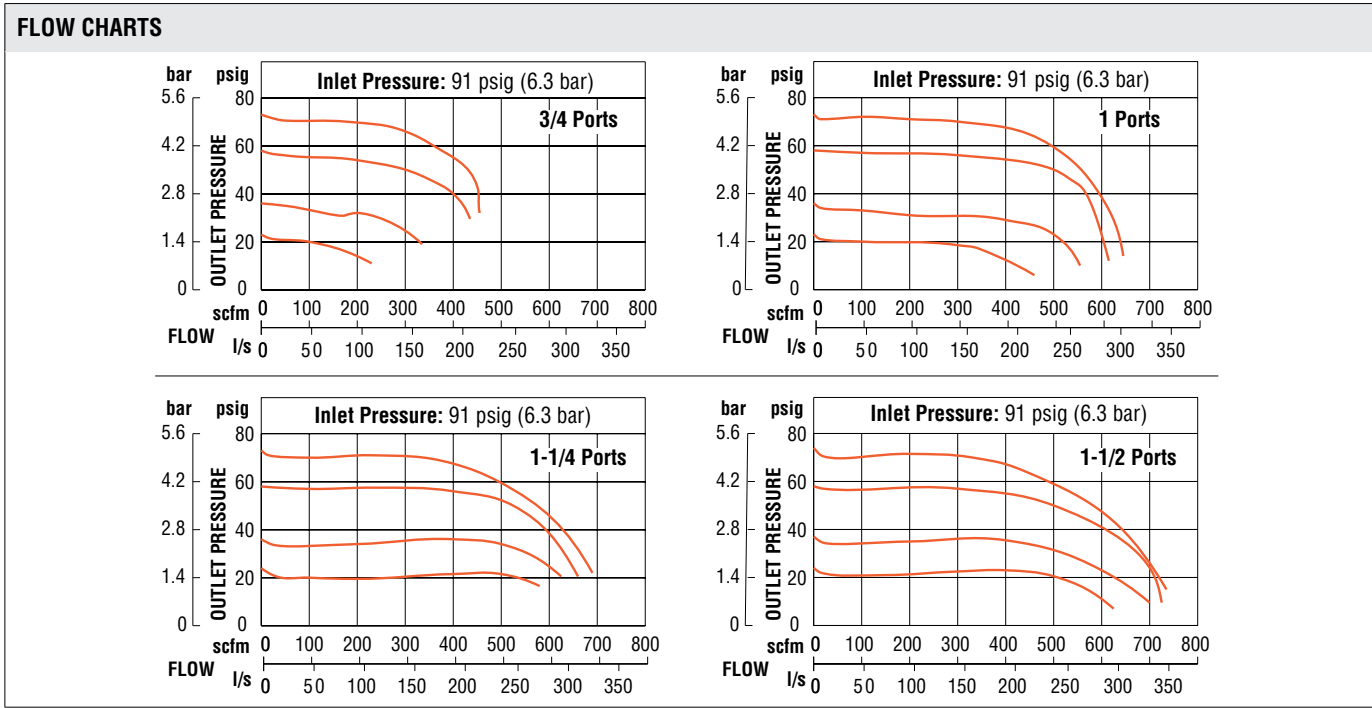

STANDARD SPECIFICATIONS

Construction Design	Diaphragm	Self-relieving
Temperature	Ambient	40° to 175°F (4° to 79°C)
	Media	
Fluid Media	Compressed air	
Operating Pressure	Inlet	Maximum 300 psig (21 bar)
	Outlet	Adjustable 0 to 200 psig (0 to 14 bar)
Pilot Ports	1/4-NPTF	
Pressure Gauge	0 to 200 psig (0 to 14 bar) standard; 1/4 NPT gauge ports front and rear	
Construction Material	Body	Aluminum
	Dome	Zinc
	Seals	Nitrile
	Valve	Brass
	Valve Cap	Nylon

In-line Premium High-Relief Remote Pilot Regulators – HIGH-CAPACITY Series

Port Sizes: 3/4, 1, 1-1/4 – Flow to 400 scfm



Port Size	Model Number	
	NPTF Thread	G Thread
3/4	5216A5007	C5216A5007
1	5216A6007	C5216A6007
1-1/4	5216A7007	C5216A7007

Pressure Gauge included.

Port Size	Dimensions inches (mm)				Weight† lb (kg)
	A	B**	C***	Depth†	
3/4, 1, 1-1/4	4.18 (117)	1.87 (47.5)	3.99 (101.3)	4.18 (106)	6.44 (3.0)

** Dome removal clearance: add 0.63 (16).
 *** Cap removal clearance: add 0.5 (13).
 † Less gauge.

ISO Symbol
 With Conventional Pilot Regulator
 Self-Relieving

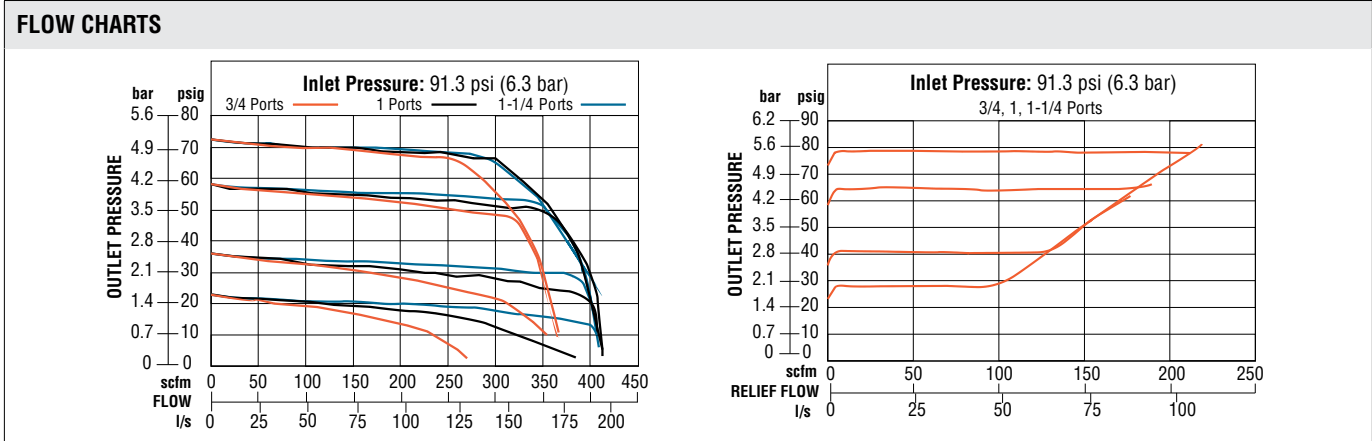
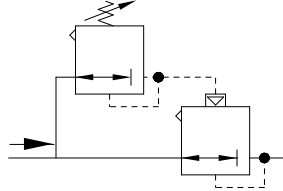

STANDARD SPECIFICATIONS

Construction Design	Diaphragm	Self-relieving
Temperature	Ambient	0° to 158°F (-18° to 70°C)
	Media	
Fluid Media	Compressed air	
Operating Pressure	Inlet	Maximum 400 psig (28 bar)
	Outlet	Adjustable up to 250 psig (up to 17 bar)
Pressure Gauge	0 to 200 psig (0 to 14 bar) standard, 1/4-NPTF (1/4 BSPP) gauge ports front and rear; 0 to 600 psig (0 to 40 bar) optional	
Construction Material	Body	Zinc
	Dome	Zinc
	Seals	Nitrile
	Valve	Brass
	Valve Cap	Glass filled Nylon

In-line Remote Pilot Regulators – HIGH-CAPACITY Series



Port Sizes: 1-1/2, 2, 3 – Flow to 4000 scfm

Flow to 850 scfm	Port Size	Model Number	
		NPTF Thread	G Thread
	1-1/2	5211B8027	C5211B8027
2	5211B9007	C5211B9007	
Pressure Gauge included.			

Flow to 4000 scfm	Port Size	Seals	Model Number	
			NPTF Thread	G Thread
	3	Nitrile	5211B9008	C5211B9008
3	Fluoroelastomer	5X00B9021	C5X00B9021	
Pressure Gauge included.				

Port Size	Dimensions inches (mm)				Weight† lb (kg)
	A	B	C	Depth†	
1-1/2, 2	6.4 (162)	5.0 (127)	3.0 (76)	2.8 (71)	8.94 (4.06)
3	8.4 (214)	7.36 (187)	3.74 (95)	8.0 (203)	21.77 (9.88)

† Less gauge.

Port Size
1-1/2, 2

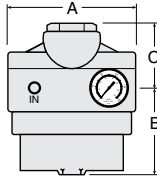

Port Size
3

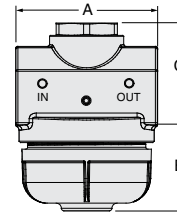

ISO Symbol Regulator

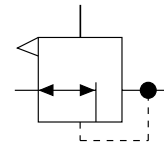

FLOW CHARTS

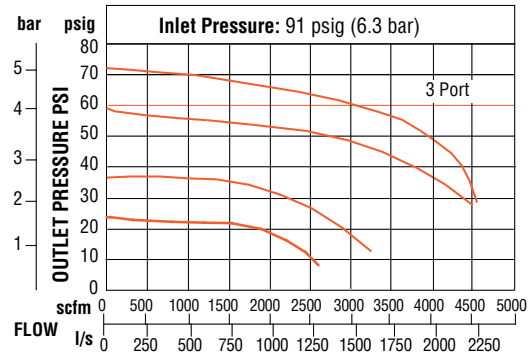
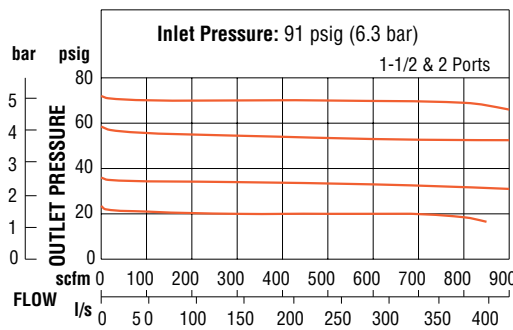

STANDARD SPECIFICATIONS

Construction Design	Piston	Self-relieving
Temperature	Ambient	40° to 175°F (4° to 79°C)
	Media	
Fluid Media	Compressed air	
Operating Pressure	Inlet	Maximum 300 psig (21 bar)
	Outlet	Adjustable 0 to 200 psig (0 to 14 bar) <i>NOTE: Outlet pressure depends on the adjustment of the pilot regulator</i>
Pilot Ports	1/4-NPTF	
Pressure Gauge	0 to 200 psig (0 to 14 bar) standard; 1/4 NPT gauge ports front and rear	
Construction Material	Body	Aluminum
	Dome	Aluminum
	Seals	Nitrile
	Valve	Brass on 1/2" & 2" ports; Aluminum on 3" ports
	Valve Cap	Aluminum

In-line Relief Valves – MINIATURE Series

Port Sizes: 1/8 & 1/4 – Flow to 40 scfm



Port Size	Port Threads	Model Number			
		Pressure Range psig (bar)			
		1-15 (0.07-1.0)	1-30 (0.07-2.1)	1-50 (0.07-3.4)	1-140 (0.07-9.6)
1/8	NPTF	5210B1002	5210B1003	5210B1004	5210B1001
	G	C5210B1002	C5210B1003	C5210B1004	C5210B1001
1/4	NPTF	5210B2002	5210B2003	5210B2004	5210B2001
	G	C5210B2002	C5210B2003	C5210B2004	C5210B2001

Pressure Gauge included.

Port Size	Dimensions inches (mm)				Weight† lb (kg)
	A	B	C	Depth†	
1/8, 1/4	1.6 (41)	2.7 (68)	0.4 (10)	1.6 (41)	0.24 (0.11)

†Less gauge.

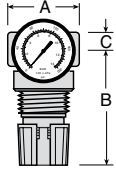
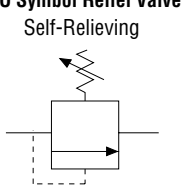
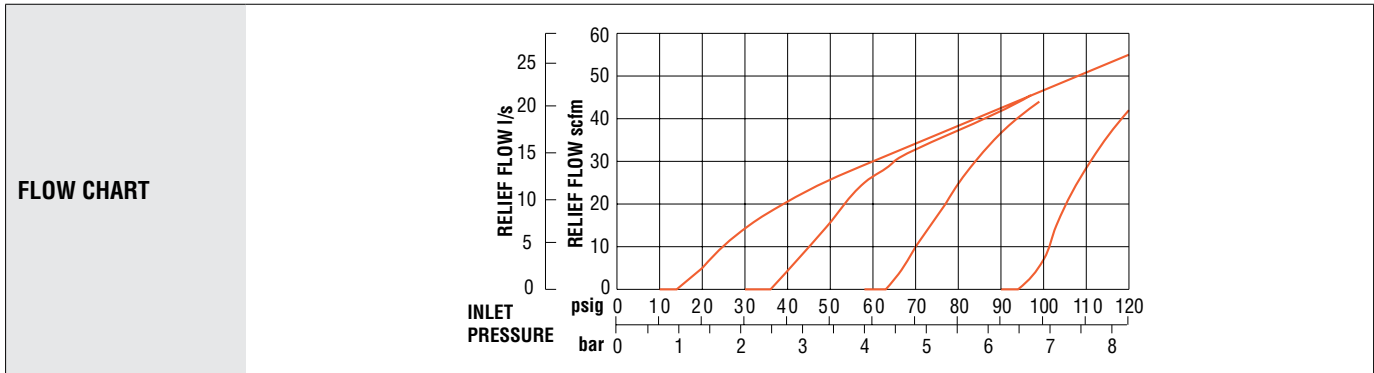
Relief Valves have maximum relief flows of 10 to 20 scfm (4.7 to 9.4 l/s). For models with increased sensitivity at lower pressure, consult ROSS.

STANDARD SPECIFICATIONS

Construction Design	Diaphragm	Self-relieving
Temperature	Ambient	40° to 125°F (4° to 52°C)
	Media	
Fluid Media	Compressed air	
Operating Pressure	Inlet	Maximum 300 psig (21 bar)
	Outlet	Adjustable 1 to 140 psig (0.07 to 9.6 bar)
Pressure Gauge	0 to 160 psig (0 to 11 bar); 1/8 NPT gauge ports front and rear	
Panel Mounting	1-3/16 inch (30 mm) hole required	
Construction Material	Body	Aluminum
	Dome	Acetal
	Knob	Acetal
	Seals	Nitrile Fluoroelastomer seals optional, consult ROSS

In-line Relief Valve – HIGH-FLOW Series



Port Sizes: 1 – Flow to 450 scfm

Port Size	Model Number	
	NPTF Thread	G Thread
1	5X00D6012	C5X00D6012



Port Size	Dimensions inches (mm)				Weight lb (kg)		
	A	B	C	Depth			
1	4.4 (111)	4.8 (122)	2.5 (62)	2.9 (72)	1.8 (0.8)		

On the right is a typical circuit using the High-Flow Relief Valve. The circuit utilizes a remotely piloted “fill” regulator (port size 1 NPT) and a small, remotely mounted, pilot regulator with 1/4 NPT ports.

The required system pressure is set by adjusting the knob on the pilot regulator until the desired system pressure is shown on the pilot regulator’s gauge. An example system pressure of 50 psig was selected in the circuit.

Outlet pressure from the pilot regulator is sent to the fill regulator’s signal port and the Port 2 of the High-Flow Relief Valve. The Port 1 of the High-Flow Relief Valve is connected to the system, as shown, to monitor system pressure.

If the system pressure exceeds the pilot regulator setting (set-point), the High-Flow Relief Valve will begin to exhaust air after an approximate 2 psig (0.1 bar) rise above the set-point.

Should the system pressure drop below the set-point, the fill valve will open to supply air downstream and maintain the system at the set-point.

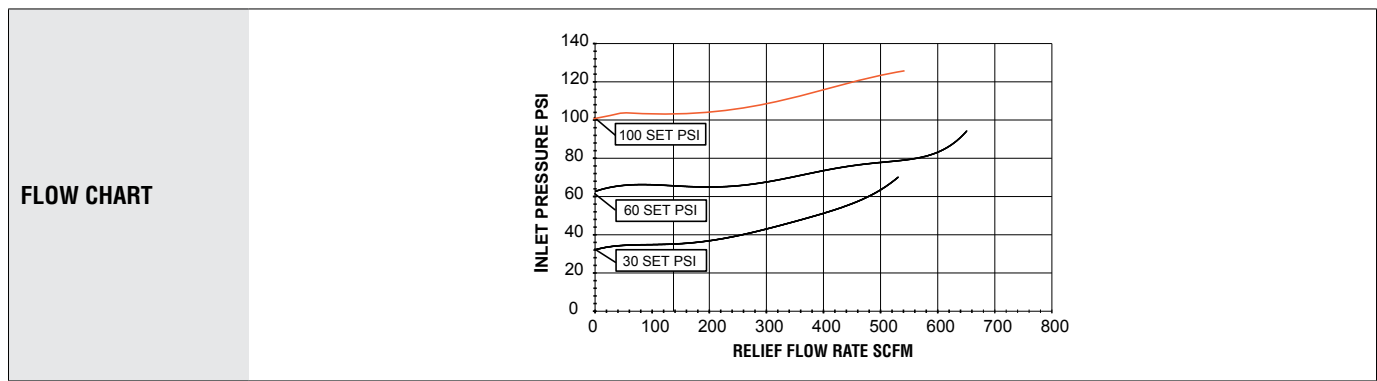
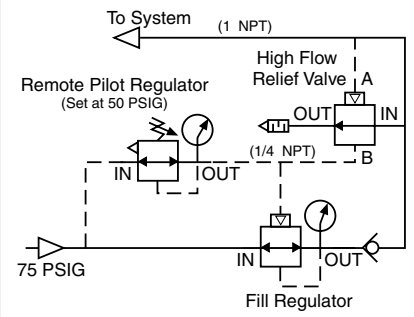

STANDARD SPECIFICATIONS

Construction Design	Diaphragm	Self-relieving
Temperature	Ambient	40° to 175°F (4° to 79°C)
	Media	
Fluid Media	Compressed air	
Operating Pressure	Inlet	Maximum 200 psig (14 bar)
	Outlet	Adjustable 0 to 200 psig (0 to 14 bar)
Pilot Ports	1/4-NPTF	
Pressure Gauge	0 to 200 psig (0 to 14 bar) standard; 1/4 NPT gauge ports front and rear	
Construction Material	Body	Aluminum
	Dome	Zinc
	Seals	Nitrile
	Valve	Brass
	Valve Cap	Nylon

Electro-Pneumatic Proportional Valves – RER1 Series

Choose your options (in red) to configure your model number.

RER1 **A** **1** **A** **100**

Connector	
6-Pin Brad Harrison	A
5-Pin M12	B

Command Input	
0-10 volts DC	1
4-20 mA	2

Maximum Calibrated Pressure Range	
0-30 psig (0 to 2.1 bar)	030
0-50 psig (0 to 3.5 bar)	050
0-100 psig (0 to 6.9 bar)	100
0-200 psig (0 to 13.8 bar)	200
0-300 psig (0 to 20.7 bar)	300
0-20 in Hg (vacuum)	V20

Monitor Signal	
0-10 volts DC	A
4-20 mA - Sinking	B
4-20 mA - Sourcing	C

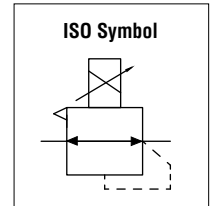

Note: High-pressure Proportional valve Q175 psi (12 bar) - inlet and exhaust ports reversed from picture shown.

ACCESSORIES

Cables For 6-Pin Brad Harrison	Cable Length	Model Number*
	6 feet (1.8 meters)	RER-CBL-6
	12 feet (3.7 meters)	RER-CBL-12
	25 feet (7.5 meters)	RER-CBL-25

*For cables for 5-Pin M12 connector, consult ROSS.



STANDARD SPECIFICATIONS

Supply Voltage/Current	15 – 24 volts DC/250 mA (required)	
Analog Monitor Signal	Voltage	0 – 10 volts DC@20 mA maximum
	Current	4 – 20 mA sinking (sourcing optional)
Command Signal Impedance	Voltage	4.7 kΩ
	Current	100 Ω
Command Signal Voltage/Current	0 – 10 volts DC/4 – 20 mA	
Electrical Connector	6-pin Brad Harrison or 5-pin M12	
Temperature	Ambient	32° to 158°F (0° to 70°C)
	Media	
Fluid Media	Compressed air	
Operating Pressure	Input	29.9 in Hg to 300 psig (760 mm Hg to 21 bar)
	Output	0 to 200 psi (0 to 14 bar)
Construction Material	Body	Zinc
	Dome	Zinc
	Housing	Aluminum; powder coated
	Manifold	Brass
	Seals	Fluorocarbon
	Transducer	Silicon, Aluminum
	Valve	Nickel-plated Brass
Accuracy	< ± 0.2% F.S.	
Linearity/Hysteresis	< ± 0.15% F.S. BFSL	
Repeatability	< ± 0.02% F.S.	

E-P Proportional Valves with Volume Booster – RB Series



Port Sizes: 1/4 to 1-1/2 – Flow to 740 scfm

Choose your options (in red) to configure your model number.

RB 1 2 A RER1 A 1 A 100

Regulator Type		
Self Relieving	1/4 to 3/4	1
	3/4 to 1-1/2	2
High-Relief	1/4 to 1/2	3
	3/4 to 1-1/4	4

Inlet/Outlet Ports Size			
NPTF		G	
1/4	2	1/4	B
3/8	3	3/8	C
1/2	4	1/2	D
3/4	6	3/4	E
1	8	1	F
1-1/4	J	1-1/4	G
1-1/2	K	1-1/2	H

Connector	
6-Pin Brad Harrison	A
5-Pin M12	B

Pressure Gauge	
Without Gauge	A
Gauge 0-200 psig (0-13.8 bar)	B
Gauge 0-600 psig (0-40 bar)	C
Gauge 0-30 psig (0-2 bar)	D
Gauge 0-60 psig (0-4 bar)	E
For Electronic Gauge, consult ROSS.	

Maximum Calibrated Pressure Range	
0-30 psig (0 to 2.1 bar)	030
0-50 psig (0 to 3.5 bar)	050
0-100 psig (0 to 6.9 bar)	100
0-200 psig (0 to 13.8 bar)	200
0-300 psig (0 to 20.7 bar)	300
0-20 in Hg (vacuum)	V20

Monitor Signal	
0-10 volts DC	A
4-20 mA - Sinking	B
4-20 mA - Sourcing	C

Command Input	
0-10 volts DC	1
4-20 mA	2

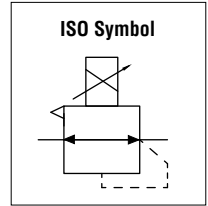

Brass Inlet Filter included.

Note: Cable not included with the product, see accessories.

Regulator Pressure Model	Inlet psi (bar)	Outlet psi (bar)	Relief scfm
RB1 - RB2	300 (20.7)	200 (13.8)	627
RB3 - RB4	400 (27.6)	250 (17.3)	200

Cables For 6-Pin Brad Harrison

Cable Length	Model Number*
6 feet (1.8 meters)	RER-CBL-6
12 feet (3.7 meters)	RER-CBL-12
25 feet (7.5 meters)	RER-CBL-25



*For cables for 5-Pin M12 connector, consult ROSS.

Mounting Bracket Kits

Regulator Type	Kit Number1
Self Relieving	RER-BRK-1
High-Relief	R-A37-381



STANDARD SPECIFICATIONS

Supply Voltage/Current	15 – 24 volts DC/250 mA (required)	
Analog Monitor Signal	Voltage	0 – 10 volts DC@20 mA maximum
	Current	4 – 20 mA sinking (sourcing optional)
Command Signal Impedance	Voltage	4.7 kQ
	Current	100 Q
Command Signal Voltage/Current	0 – 10 volts DC/4 – 20 mA	
Electrical Connector	6-pin Brad Harrison or 5-pin M12	
Temperature	Ambient & Media	32° to 158°F (0° to 70°C)
Fluid Media	Compressed air	
Operating Pressure	Input	29.9 in Hg to 300 psig (760 mm Hg to 21 bar)
	Output	0 to 200 psi (0 to 14 bar)
Construction Material	Body & Dome	Zinc
	Housing	Aluminum; powder coated
	Manifold	Brass
	Seals	Fluorocarbon
	Transducer	Silicon, Aluminum
	Valve	Nickel-plated Brass
Accuracy	< ± 2.5% F.S.	
Linearity/Hysteresis	< ± 2.0% F.S. BFSL	
Repeatability	< ± 0.6% F.S.	

Accessories

MOUNTING ACCESSORIE BRACKETS & BRACKET KIT

Mounting Screws for BANTAM Models	Kit Number	BANTAM models mounts with long screws that extend through end plates.								
	859K77									
Mounting Brackets	Usage Models	Model Number			Dimensions inches (mm)					
		Kit	Bracket	Panel Nut	A	B	C	D	E	Panel Mounting Hole Diameter
	MINIATURE	873K77	872K77	874K77	1.375 (35)	1.125 (29)	0.31 (8)	0.31 (8)	0.69 (17)	1.19 (30)
	MID-SIZE	876K77	875K77	877K77	2.38 (60)	1.00 (25)	1.50 (38)	-	-	1.56 (40)
	MD3™	R-A127-11	-	R-127-11	2.38 (60)	1.00 (25)	1.50 (38)	-	-	2.06 (52)
	FULL-SIZE, MD4™	879K77	878K77	880K77						
Regulators and integrated filter/regulators can be mounted to a surface with a bracket that attaches to the regulator. Brackets and mounting panel nuts can be ordered separately or in a kit which includes both bracket and mounting panel nut.										
Modular Mounting Brackets	Usage Models	Kit Number	Dimensions inches (mm)							
	MID-SIZE & FULL-SIZE	915K77	A	B	C					
Two L-shaped metal brackets as shown at the right can be used for wall mounting of modular FRLs or Clean Air Packages. A single bracket can be used to mount individual filters or lubricators. Kits include two brackets and four screws for attaching the brackets to the modules.										
FRLs In-line Mounting Pipe Brackets	Nipple Size	Kit Number	Dimensions inches (mm)							
	1/4	887K77	2.72 (28)	0.50 (13)	1.00 (25)					
	3/8	888K77								
	1/2	889K77	3.69 (94)	1.13 (29)	1.25 (32)					
	3/4	890K77								
	1	891K77								
Two pipe brackets can be used for wall mounting of FRLs assemblies that use pipe nipples to join the components. The bracket kits listed below include two sets of brackets.										
Mounting Bracket Assembly Kit for Pilot Operated Regulator	Regulator Type	Kit Number1								
	Self Relieving	RER-BRK-1								
	High-Relief	R-A37-381								
	High-Relief Pilot Operated Regulator with 1/4- thru 1¼ inch ports can be mounted to a vertical surface using a bracket assembly kit.									

MODULAR ASSEMBLY COMPONENTS – MID-SIZE, FULL-SIZE & BANTAM SERIES

MID-SIZE and FULL-SIZE Units

Connector Kit	Kit Number	
	892K77	
Used to connect units to one another as well as to any of the ports shown on this page.		

The modular designs of the MID-SIZE and FULL-SIZE series offer maximum flexibility in customizing FRLs assemblies. As shown at the right, connector kits are required to interconnect units. Various port kits (shown below) can be used to connect the assemblies to the inlet and outlet piping. Note that all FRLs components have threaded ports so that conventional pipe fittings may be used where desired.

Female Port Blocks	Port Size	Model Number		
		NPTF Thread	G Thread	
	1/4	897K77	D897K77	
	3/8	898K77	D898K77	
	1/2	899K77	D899K77	
3/4	900K77	D900K77		
Used to connect to piping at inlet or outlet.				

Male Port Blocks	Port Size	Model Number		
		NPTF Thread	G Thread	
	1/4	893K77	D893K77	
	3/8	894K77	D894K77	
	1/2	895K77	D895K77	
3/4	896K77	D896K77		
Used to connect modular to non-modular units.				

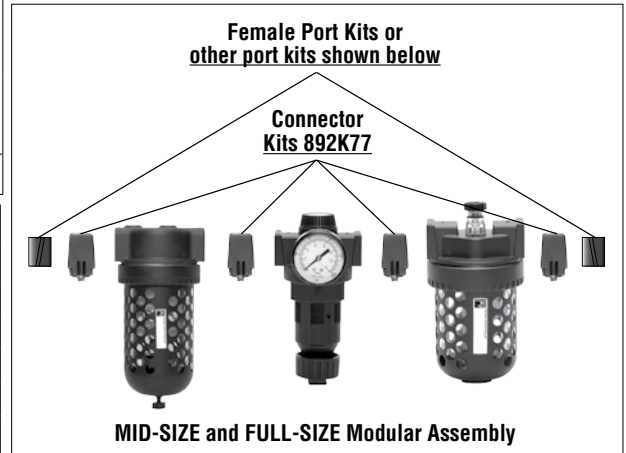

BANTAM Units

End Plate & Connections	Description	Model Number	
	END PLATE (1)	857K77	
	Short Screw (2)	858K77	
	Long Screw (2)	859K77	
	Small O-Ring (for inlet or mating ports)	860K77	
Large O-Ring (for outlet or mating ports)	861K77		

BANTAM modular units use end plates secured with screws to hold the pipe or tubing ports (see below), and also to serve as mounting brackets. Short screws are used to secure the end plates when a single BANTAM unit is used. If two or more units are combined, long screws extend through an end plate and thread into the next unit.

Screw kits required are as follows:

Single Unit: Two short screw kits.

Two-Unit Combination: One each short screw kit and long screw kit.

Three-Unit Combination: Two long screw kits.

Pipe Ports	Port Size	Model Number		
		NPTF Thread	G Thread	
	1/8	862K77	D864K77	
1/4	863K77	D865K77		

Tube Ports	Port Size	Model Number	
	1/4	866K77	
	3/8	867K77	
	4 mm	868K77	
	6 mm	869K77	
	8 mm	870K77	
10 mm	871K77		

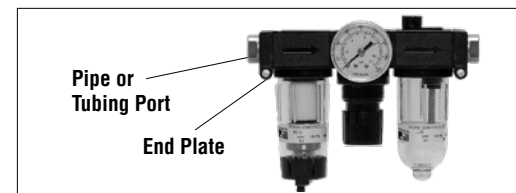

Accessories

MODULAR CONNECTION







Clamp	Bracket, Screw, and Clamp	Mounting Bracket
		
Extra Port Blocks	Female End Ports	Male End Ports
		

Illustration example.

Mounting Brackets & Clamp for Module Connections	Options	Model Number
	Clamp only	R-A118-105
	Bracket, Screw, and Clamp	R-A118-105M
<p>Two brackets are normally used to mount an FRL to a vertical surface. The mounting bracket attaches to the module connecting clamp (see above) with a single screw. Each bracket then employs two bolts (1/4" or 6mm) to connect the assembly to the mounting surface.</p> <p>Specially designed clamps provide a quick and easy assembly or disassembly of MD3™ modules. Two Allen-Head bolts quickly tighten or loosen the clamp using a 5/32 or 4mm hex key. The clamp contains a plate carrying two O-rings to provide positive sealing between modules.</p>		

Extra Port Blocks	Port Size	Model Number	
		NPTF Thread	G Thread
	1/4	R-118-106-2	R-118-106-2W
	3/8	R-118-106-3	R-118-106-3W
	1/2	R-118-106-4	R-118-106-4W
<p>An extra port block can be placed between modules to provide two auxiliary 1/4 NPTF ports. Its mounting position can be rotated to obtain the most convenient operating orientation. If only one auxiliary port is to be used, the unused port must be closed with a pipe plug. (The inlet and outlet are not threaded.)</p>			

Male and Female End Ports	Options	Port Size	Model Number	
			NPTF Thread	G Thread
	Male End Ports	1/2	R-118-109-4F	R-118-109-4FW
		3/4	R-118-109-6F	R-118-109-6FW
	Female End Ports	1/2	R-118-100-4	R-118-100-4W
3/4		R-118-100-6	R-118-100-6W	
<p>Either male or female end ports can be attached to threaded inlet and outlet lines. This allows all modules of an FRL assembly to be removed easily and quickly without having to unthread the end modules. The end ports are attached to the modules with clamps (see at left). End ports can be included in an assembled FRL or ordered separately.</p>				

LUBRICANTS, POLYCARBONATE BOWL CAUTIONS

COMPATIBLE LUBRICANTS

Although air line lubrication is not required for most ROSS valves, other mechanisms in the system may need such lubrication. When a lubricator is used, it should be supplied only with oils which are compatible with the materials used in the valves for seals and poppets. Generally speaking, these are petroleum base oils with oxidation inhibitors, and aniline point between 180°F (82°C) and 220°F (104°C) and an ISO 32, or lighter, viscosity. Oils with phosphate type additives, such as zinc dithiophosphate, must be avoided because they can harm polyurethane valve components. The best oils to use in pneumatic systems are those specifically compounded for air line lubricator service.

CAUTIONS ON THE USE OF POLYCARBONATE BOWLS

Use Only with Compressed Air. Filters and lubricators with polycarbonate bowls are specifically designed for compressed air service, and their use with any other fluid (liquid or gas) is a misapplication. The use with or injection of certain hazardous fluids in the system (e.g., alcohol or liquefied petroleum gas) could be harmful to the polycarbonate bowl or result in a combustible condition or hazardous leakage. Before using with a fluid other than air, or for nonindustrial applications, or for life support systems, consult ROSS.

Use Metal Bowl Guard When Supplied. A metal bowl guard is supplied with all but the smallest bowls, and must always be used to minimize danger from fragmentation in the event of failure of a polycarbonate bowl.

Avoid Harmful Substances. Some compressor oils, chemical cleaners, solvents, paints, and fumes will attack polycarbonate bowls and can cause bowl failure. Do not use with or near these materials. When a bowl becomes dirty, replace the bowl or wipe it with a clean dry cloth. Immediately replace any polycarbonate bowl which is crazed, cracked, or deteriorated.

SUBSTANCES HARMFUL TO POLYCARBONATE BOWLS

Acetaldehyde	Carbon disulfide	Ethylene dichloride	Phosphorous trichloride
Acetic acid	Carbon tetrachloride	Ethylene glycol	Propionic acid
Acetone	Caustic potash solution	Formic acid	Pyridine
Acrylonitrile	Caustic soda solution	Freon (refrigerant & propellant)	Sodium hydroxide
Ammonia	Chlorobenzene	Gasoline (high aromatic)	Sodium sulfide
Ammonium fluoride	Chloroform	Hydrazine	Styrene
Ammonium hydroxide	Cresol	Hydrochloric acid	Sulfuric acid
Ammonium sulfide	Cyclohexanol	Lacquer thinner	Sulfural chloride
Anaerobic adhesives & sealants	Cyclohexanone	Methyl alcohol	Tetrahydronaphthalene
Antifreeze	Cyclohexene	Methylene chloride	Thiophene
Benzene	Dimethyl formamide	Methylene salicylate	Toluene
Benzoic acid	Dioxane	Milk of lime (CaOH)	Turpentine
Benzyl alcohol	Ethane tetrachloride	Nitric acid	Xylene
Brake fluids	Ethyl acetate	Nitrobenzene	Perchloroethylene
Bromobenzene	Ethyl ether	Nitrocellulose lacquer	
Butyric acid	Ethylamine	Phenol	
Carbolic acid	Ethylene chlorohydrin	Phosphorous hydroxyl chloride	

TRADE NAMES OF SUBSTANCES HARMFUL TO POLYCARBONATE BOWLS

Atlas Perma-Guard	Loctite Threadlocker Red 271	Pydraul AC
Buna-N	Loctite Threadlocker 290	Sears Regular Motor Oil
Cellulube #150 & #220	Loctite 601	Sinclair oil "Lily White"
Crylex #5 Cement	Loctite Teflon Sealant	Stauffer Chemical FYRQUEL 150
Eastman 910	Marvel Mystery Oil	Stillman #SR 269-75 (polyurethane)
Garlock #98403 (polyurethane)	Minnesota Rubber 366Y	Stillman #SR 513-70 (neoprene)
Haskel #568-023	National Compound #N11	Tannergas
Hilgard Company's Hil-Phene	Nylock VC-3	Telar
Houghton & Co. Oil #1120, #1130, #1055	Parco #1306 Neoprene	Tenneco Anderol 495 & 500 Oils
Houtosafe 1000	Permabond 910	Titon
Kano Kroil	Petron PD287	Vibra-TITE
Keystone penetrating Oil #2	Prestone	Valvolin ZEREX

CAUTIONS, WARNINGS And STANDARD WARRANTY



ROSS OPERATING VALVE, ROSS CONTROLS®, ROSS DECCO®, and AUTOMATIC VALVE INDUSTRIAL, collectively the "ROSS Group".

PRE-INSTALLATION or SERVICE

1. Before servicing a valve or other pneumatic component, be sure all sources of energy are turned off, the entire pneumatic system is shut down and exhausted, and all power sources are locked out (ref: OSHA 1910.147, EN 1037).
2. All ROSS Group Products, including service kits and parts, should be installed and/or serviced only by persons having training and experience with pneumatic equipment. Because any product can be tampered with and/or need servicing after installation, persons responsible for the safety of others or the care of equipment must check ROSS Group Products on a regular basis and perform all necessary maintenance to ensure safe operating conditions.
3. All applicable instructions should be read and complied with before using any fluid power system to prevent harm to persons or equipment. In addition, overhauled or serviced valves must be functionally tested prior to installation and use. If you have any questions, call your nearest ROSS Group location.
4. Each ROSS Group Product should be used within its specification limits. In addition, use only ROSS Group components to repair ROSS Group Products.

WARNINGS:

Failure to follow these instructions can result in personal injury and/or property damage.

FILTRATION and LUBRICATION

1. Dirt, scale, moisture, etc., are present in virtually every air system. Although some valves are more tolerant of these contaminants than others, best performance will be realized if a filter is installed to clean the air supply, thus preventing contaminants from interfering with the proper performance of the equipment. The ROSS Group recommends a filter with a 5-micron rating for normal applications.
2. All standard ROSS Group filters and lubricators with polycarbonate plastic bowls are designed for compressed air applications only. Use the metal bowl guard, where provided, to minimize danger from high pressure fragmentation in the event of bowl failure. Do not expose these products to certain fluids, such as alcohol or liquefied petroleum gas, as they can cause bowls to rupture, creating a combustible condition and hazardous leakage. Immediately replace crazed, cracked, or deteriorated bowls.
3. Only use lubricants which are compatible with materials used in the valves and other components in the system. Normally, compatible lubricants are petroleum base oils with oxidation inhibitors, an aniline point between 180°F (82°C) and 220°F (104°C), and an ISO 32, or lighter, viscosity. Avoid oils with

phosphate type additives which can harm polyurethane components, potentially leading to valve failure which risks personal injury, and/or damage to property.

WARNINGS:

Failure to follow these instructions can result in personal injury and/or property damage.

AVOID INTAKE/EXHAUST RESTRICTION

1. Do not restrict air flow in the supply line. To do so could reduce the pressure of the supply air below minimum requirements for the valve and thereby causing erratic action.
2. Do not restrict a valve's exhaust port as this can adversely affect its operation. Exhaust silencers must be resistant to clogging and must have flow capacities at least as great as the exhaust capacities of the valves. Contamination of the silencer can result in reduced flow and increased back pressure.

WARNINGS: Failure to follow these instructions can result in personal injury and/or property damage.

SAFETY APPLICATIONS

1. Mechanical Power Presses and other potentially hazardous machinery using a pneumatically controlled clutch and brake mechanism must use a press control double valve with a monitoring device. A double valve without a self-contained monitoring device should be used only in conjunction with a control system which assures monitoring of the valve. All double valve installations involving hazardous applications should incorporate a monitoring system which inhibits further operation of the valve and machine in the event of a failure within the valve mechanism.
2. Safe Exhaust (dump) valves without a self-contained monitoring device should be used only in conjunction with a control system which assures monitoring of the valve. All Safe Exhaust valve installations should incorporate a monitoring system which inhibits further operation of the valve and machine in the event of a failure within the valve mechanism.
3. Per specifications and regulations, the ROSS L-O-X® and L-O-X® with EEZ-ON®, N06 and N16 Series operation products are defined as energy isolation devices, NOT AS EMERGENCY STOP DEVICES.

WARNINGS:

Failure to follow these instructions can result in personal injury and/or property damage.

STANDARD WARRANTY

All products sold by the ROSS Group are warranted for a one-year period [with the exception of Filters, Regulators and Lubricators ("FRLs") which are warranted for a period of seven (7) years] from the date of purchase. All products are, during their respective warranty periods, warranted to be free of defects in material and workmanship. The ROSS Group's obligation under this warranty is limited to repair, replacement or refund of the purchase price paid for products which the ROSS Group has determined, in its sole discretion, are defective. All warranties become void if a product has been subject to misuse, misapplication, improper maintenance, modification or tampering. Products for which warranty protection is sought must be returned to the ROSS Group freight prepaid.

THE WARRANTY EXPRESSED ABOVE IS IN LIEU OF AND EXCLUSIVE OF ALL OTHER WARRANTIES AND THE ROSS GROUP EXPRESSLY DISCLAIMS ALL OTHER WARRANTIES EITHER EXPRESSED OR IMPLIED WITH RESPECT TO MERCHANTABILITY OR FITNESS FOR A PARTICULAR PURPOSE. THE ROSS GROUP MAKES NO WARRANTY WITH RESPECT TO ITS PRODUCTS MEETING THE PROVISIONS OF ANY GOVERNMENTAL OCCUPATIONAL SAFETY AND/OR HEALTH LAWS OR REGULATIONS. IN NO EVENT IS THE ROSS GROUP LIABLE TO PURCHASER, USER, THEIR EMPLOYEES OR OTHERS FOR INCIDENTAL OR CONSEQUENTIAL DAMAGES WHICH MAY RESULT FROM A BREACH OF THE WARRANTY DESCRIBED ABOVE OR THE USE OR MISUSE OF THE PRODUCTS. NO STATEMENT OF ANY REPRESENTATIVE OR EMPLOYEE OF THE ROSS GROUP MAY EXTEND THE LIABILITY OF THE ROSS GROUP AS SET FORTH HEREIN.



AMERICAS	ROSS CONTROLS	USA	Tel: +1-248-764-1800	www.rosscontrols.com
	ROSS CONTROLS CANADA Ltd.	Canada	Tel: +1-416-251-7677	www.rosscanada.com
	ROSS DO BRASIL LTDA	Brazil	Tel: +55-11-4335-2200	www.rosscontrols.com.br
EUROPE	ROSS EUROPA GmbH	Germany	Tel: +49 (0)6103-7597-100	www.rosseuropa.com
	ROSS FRANCE SAS	France	Tel: +33-(0)1-49-45-65-65	www.rossfrance.com
	ROSS PNEUMATROL Ltd.	United Kingdom	Tel: +44 (0)1254 872277	www.rossuk.co.uk
ASIA & PACIFIC	ROSS CONTROLS INDIA Pvt. Ltd.	India	Tel: +91-44-2624-9040	www.rosscontrolsindia.com
	ROSS CONTROLS (CHINA) Ltd.	China	Tel: +86-21-6915-7961	www.rosscontrolschina.com
	ROSS ASIA K.K.	Japan	Tel: +81-42-778-7251	www.rossasia.co.jp
	AUTOMATIC VALVE INDUSTRIAL LLC	USA	Tel: +1-248-474-6700	www.automaticvalve.com
	ROSS DECCO COMPANY	USA	Tel: +1-248-764-1800	www.rossdecco.com
	ROSS PNEUMATROL Ltd.	United Kingdom	Tel: +44 (0)1254 872277	www.pneumatrol.com
	manufactIS GmbH	Germany	Tel: +49 (0)2013-16843-0	www.manufactis.net

Full-Service Global Locations

There are ROSS Distributors Throughout the World

To meet your requirements across the globe, ROSS distributors are located throughout the world. Through ROSS or its distributors, guidance is available for the selection of ROSS products, both for those using fluid power components for the first time and those designing complex systems.

Other literature is available for engineering, maintenance, and service requirements.

If you need products or specifications not shown in this catalog, please visit ROSS' website, contact ROSS or your ROSS distributor. The ROSS Support Team will be happy to assist you in selecting the best product for your application.

For a current list of countries and local distributors, visit ROSS' at www.rosscontrols.com.