



FLOW CONTROL VALVES 19 & 11 SERIES

PRODUCT CATALOG



Flow Control Valves 19 & 11 Series

Product Overview

Flow Control Function

Flow control valves provide high air flow rates into a cylinder, and precisely controlled flow rates out of the cylinder. The adjustable flow can range from near zero to full flow.







Low-Profile		Heavy-Duty		Right-Angle	
with Slot Adjustment	with Knob Adjustment	High-Capacity	Low-Profile High-Capacity	with Slot Adjustment	with Knob Adjustment
					

Illustration examples.

Valve Schematic

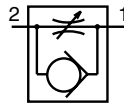

Selecting flow control valves with sufficient flow capacity is important so that they do not become the limiting factor in the cylinder control system. Full flow capacity should match that of the control valve to keep cylinder motion smooth and predictable in both directions.

VALVE FEATURES

Poppet Design	Dirt-tolerant poppet design; available in alternate materials for extreme temperature applications
High Flow	High flow capacity in free-flow direction (port 1 to 2), same high flow available in reverse direction
Visible Indication	Low-Profile High-Capacity valves – Brass stem gives visible indication of flow rate in controlled direction (port 2 to 1)
Positive Locking	Low-Profile High-Capacity valves – Prevents change of adjustment knob due to vibration or tampering
Adjustable Flow	Knob hand or screwdriver slot adjustment to control flow

STANDARD SPECIFICATIONS

GENERAL	Function		2/2 Valve	
	Construction Design		Poppet	
	Actuation		Pneumatic	
	Mounting	Type	Low-Profile	Inline
			High-Capacity	
			Low-Profile High-Capacity	
			Right-Angle	Screws directly into cylinder port
	Orientation	Orientation	Low-Profile	Any, preferably vertical
			High-Capacity	Inline, Offset
			Low-Profile High-Capacity	
Right-Angle			Inlet port can be swiveled 360° for optimum placement	
Connection		Threaded	NPT, G	
OPERATING CONDITIONS	Temperature	Low-Profile	Ambient	41° to 140°F (5° to 60°C)
			Media	
		High-Capacity Low-Profile High-Capacity	Ambient	-40° to 175°F (-40° to 80°C)
			Media	
			<i>For temperatures below 40° F (4° C) air must be free of water vapor to prevent formation of ice.</i>	
			<i>For temperatures below -40° F (-40° C), consult ROSS.</i>	
		Right-Angle	Ambient	40° to 175°F (4° to 80°C)
			Media	
	Flow Media		Filtered air	
	Operating Pressure	Low-Profile	Supply Pressure	217 psi (15 bar)
Maximum Pressure			150 psi (10 bar)	
High-Capacity		5 to 150 psig (0.3 to 10 bar)		
Low-Profile High-Capacity				
Right-Angle				
CONSTRUCTION MATERIAL	Valve Body	Low-Profile	Cast Aluminum	
		High-Capacity		
		Low-Profile High-Capacity		
		Right-Angle	Nickel-plated brass body, black anodized aluminum swivel	
	Poppet		Acetal and Stainless Steel	
	Spring	Right-Angle	Stainless Steel	
	Seals		Buna-N	

IMPORTANT NOTE: Please read carefully and thoroughly all of the CAUTIONS, WARNINGS on the inside back cover.

PRODUCT CREDENTIALS

EAC Conformity Declaration



Ordering Information

FLOW CONTROL VALVES				2-Way Valves	
Valve Style		Body Size	Port Size	Valve Model Number	
			In-Out	NPT Thread	G Thread
Low-PROFILE	with Slot Adjustment	1/8	1/8	1968F1004	D1968F1004
		1/4	1/4	1968F2004	D1968F2004
	with Knob Adjustment	3/8	1/4	1968F2007	D1968F2007
			3/8	1968F3007	D1968F3007
			1/2	1968F4007	D1968F4007
HIGH-CAPACITY	3/8	1/4	1968B2007	D1968B2007	
		3/8	1968B3007	D1968B3007	
		1/2	1968B4017	D1968B4017	
	3/4	1/2	1968B4007	D1968B4007	
		3/4	1968B5007	D1968B5007	
		1	1968B6017	D1968B6017	
	1-1/4	1	1968B6007	D1968B6007	
		1-1/4	1968B7007	D1968B7007	
		1-1/2	1968B8017	D1968B8017	
	2	1-1/2	1968B8007	D1968B8007	
		2	1968B9007	D1968B9007	
2-1/2		1968B9017	D1968B9017		
Low-PROFILE HIGH-CAPACITY	3/4	1/2	1968E4007	D1968E4007	
		3/4	1968E5007	D1968E5007	
	1-1/4	1	1968E6007	D1968E6007	
		1-1/2	1968E7007	D1968E7007	

Valve Style		Size		Flow C _v (NI/min)	Weight lb (kg)
		Body	Port 1, 2	1-2	
Low-PROFILE	with Slot Adjustment	1/8	1/8	0.5 (490)	0.1 (0.1)
		1/4	1/4	0.5 (490)	
	with Knob Adjustment	3/8	1/4, 3/8, 1/2	2.3 (2300)	0.4 (0.2)
HIGH-CAPACITY	3/8	1/4	2.3 (2300)	0.5 (0.2)	
		3/8, 1/2	2.6 (2600)		
	3/4	1/2	7.5 (7400)	0.8 (0.4)	
		3/4, 1	8.3 (8200)		
	1-1/4	1	17 (17000)	2.2 (1.0)	
		1-1/4	22 (22000)		
		1-1/2	23 (22000)		
2	1-1/2, 2, 2-1/2	50 (49000)	4.3 (1.9)		
Low-PROFILE HIGH-CAPACITY	3/4	1/2	7.5 (7400)	0.8 (0.4)	
		3/4	8.3 (8200)		
	1-1/4	1	17 (17000)	2.1 (1.0)	
		1-1/2	22 (22000)		

FLOW CONTROL VALVES 2-Way Valves

Valve Style		Connection	Body Size	Port Size	Valve Model Number	
				In-Out	NPT Thread	G Thread
RIGHT-ANGLE	with Slot Adjustment	Threaded Inlet	1/4	1/8	1968A1008	D1968A1008
				1/4	1968A2008	D1968A2008
			3/8	3/8	1968A3008	D1968A3008
				1/2	1968A4008	D1968A4008
		Tube Fitting	1/4	1/8	1968A1108 #	-
				1/4	1968A2108	-
			3/8	3/8	1968A3108	D1968A3108
				1/2	-	-
	with Knob Adjustment	Threaded Inlet	1/4	1/8	1968A1008	-
				1/4	1968A2018	D1968A2018
			3/8	3/8	1968A3018	D1968A3018
				1/2	1968A4018	D1968A4018
		Tube Fitting	1/4	1/8	1968A1118 #	D1968A1118 #
				1/4	1968A2118	D1968A2118
			3/8	3/8	1968A3118	D1968A3118
				1/2	-	-

These models have 1/8 threaded outlet, but with 1/4 inlet tube fittings.

Valve Style		Connection	Size		Flow C _v (NI/min)	Weight lb (kg)
			Body	Port 1, 2	1-2	
RIGHT-ANGLE	with Slot Adjustment	Threaded Inlet	1/4	1/8	0.3 (300)	0.06 (0.03)
				1/4	0.6 (590)	0.12 (0.05)
			3/8	3/8	1.9 (1900)	0.20 (0.09)
				1/2	2.8 (2800)	0.34 (0.15)
		Tube Fitting	1/4	1/8	0.3 (300)	0.06 (0.03)
				1/4	0.6 (590)	0.12 (0.05)
			3/8	3/8	1.9 (1900)	0.20 (0.09)
				1/2	2.8 (2800)	0.34 (0.15)
	with Knob Adjustment	Threaded Inlet	1/4	1/8	0.3 (300)	0.08 (0.04)
				1/4	0.6 (590)	0.14 (0.06)
			3/8	3/8	1.9 (1900)	0.20 (0.09)
				1/2	2.8 (2800)	0.34 (0.15)
		Tube Fitting	1/4	1/8	0.3 (300)	0.08 (0.04)
				1/4	0.6 (590)	0.14 (0.06)
			3/8	3/8	1.9 (1900)	0.20 (0.09)
				1/2	2.8 (2800)	0.34 (0.15)

Valve Technical Data

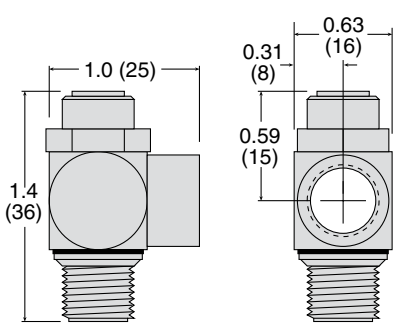
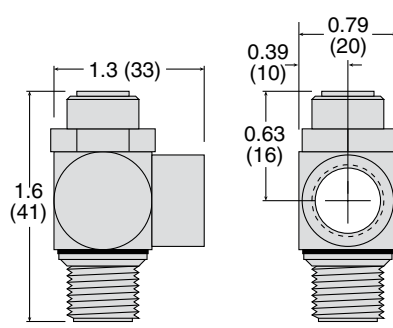
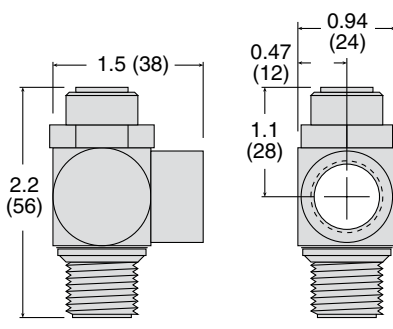
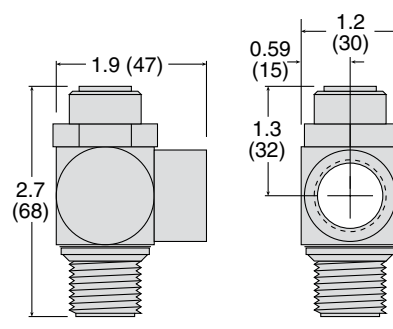
DIMENSIONS		Inches (mm)
Right Angle	Body Size 1/8	
	Body Size 1/4	
	Body Size 3/8	
	Body Size 1/2	
Downloadable CAD models available.		

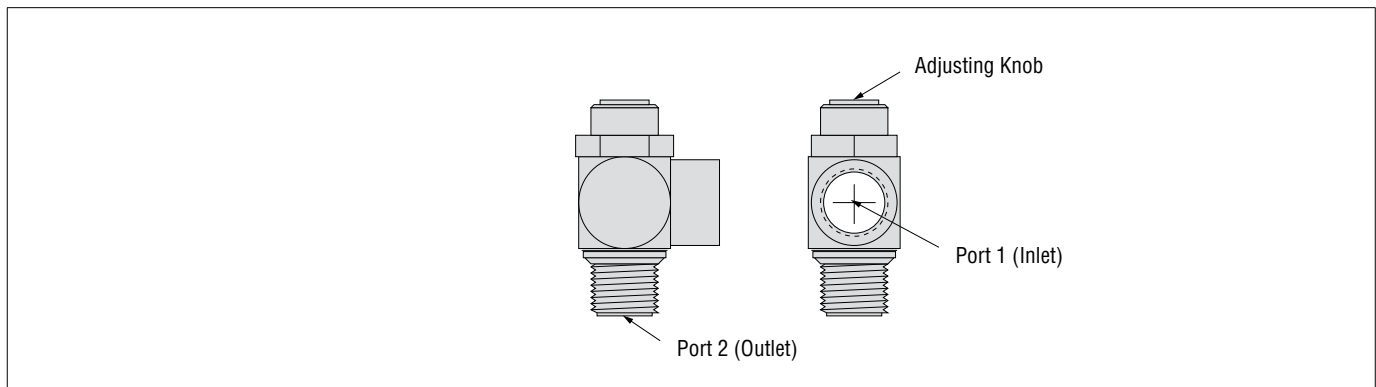

DIMENSIONS		Inches (mm)	
with Slot Adjustment	Body Size 1/8		
	Body Size 1/4		
Low-Profile	Body Size 3/8		
with Knob Adjustment			
Downloadable CAD models available.			

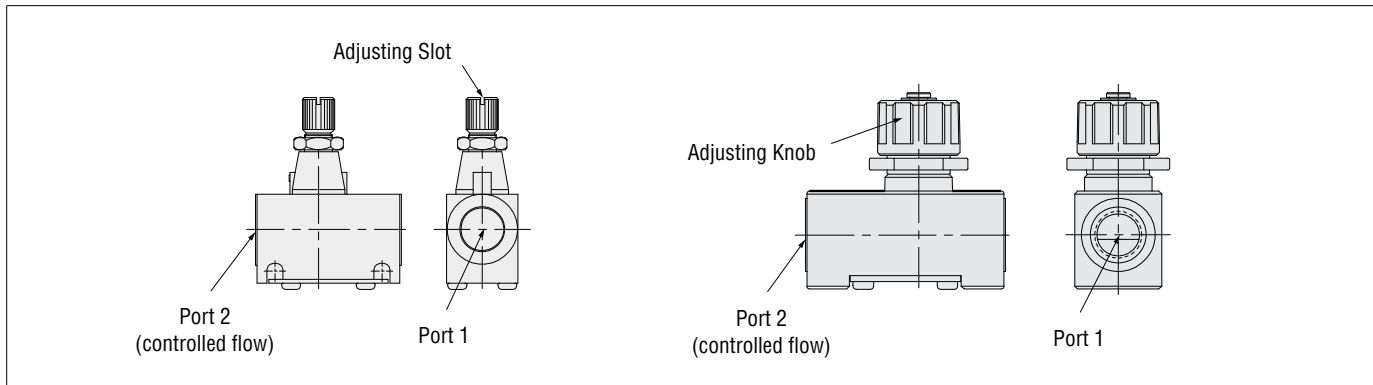

Valve Technical Data

DIMENSIONS		Inches (mm)
High-Capacity	Body Size 3/8	
	Body Size 3/4	
	Body Size 1-1/4	
	Body Size 2	
Downloadable CAD models available.		

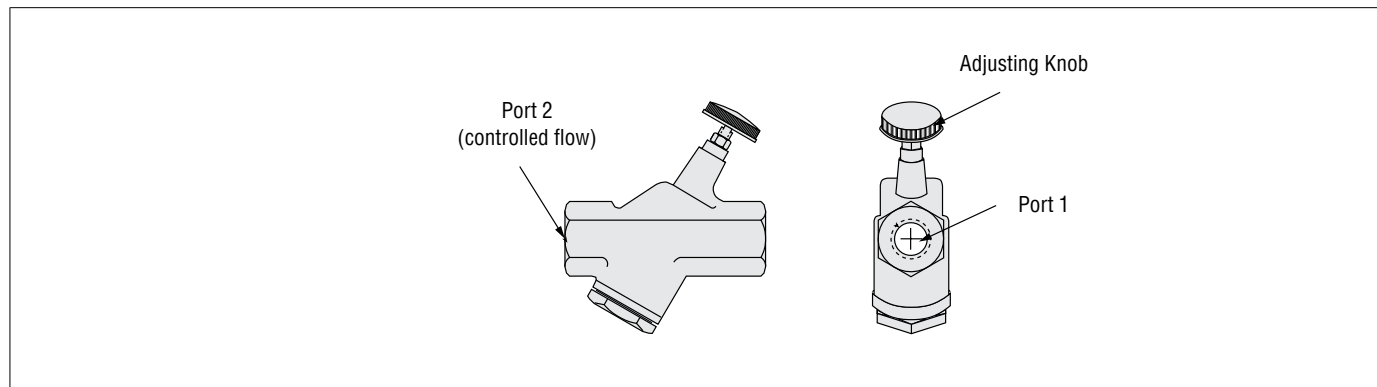

DIMENSIONS

Inches (mm)

Body Size 3/4

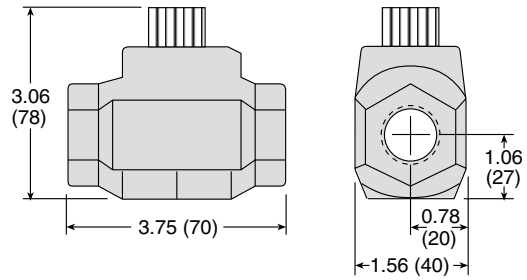

Low-Profile High-Capacity

Body Size 1-1/4

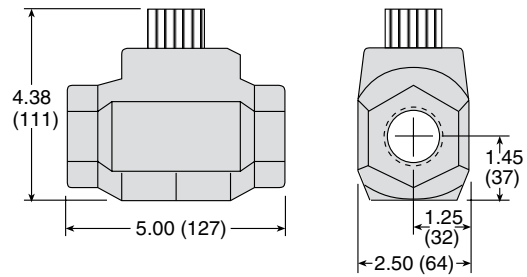

Downloadable CAD models available.

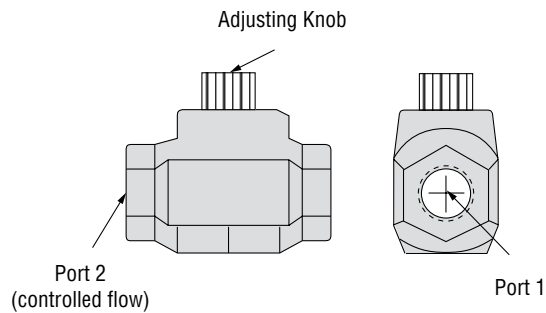

CAUTIONS, WARNINGS And STANDARD WARRANTY



ROSS OPERATING VALVE, ROSS CONTROLS®, ROSS DECCO®, and AUTOMATIC VALVE INDUSTRIAL, collectively the “ROSS Group”.

PRE-INSTALLATION or SERVICE

1. Before servicing a valve or other pneumatic component, be sure all sources of energy are turned off, the entire pneumatic system is shut down and exhausted, and all power sources are locked out (ref: OSHA 1910.147, EN 1037).
2. All ROSS Group Products, including service kits and parts, should be installed and/or serviced only by persons having training and experience with pneumatic equipment. Because any product can be tampered with and/or need servicing after installation, persons responsible for the safety of others or the care of equipment must check ROSS Group Products on a regular basis and perform all necessary maintenance to ensure safe operating conditions.
3. All applicable instructions should be read and complied with before using any fluid power system to prevent harm to persons or equipment. In addition, overhauled or serviced valves must be functionally tested prior to installation and use. If you have any questions, call your nearest ROSS Group location.
4. Each ROSS Group Product should be used within its specification limits. In addition, use only ROSS Group components to repair ROSS Group Products.

WARNINGS:

Failure to follow these instructions can result in personal injury and/or property damage.

FILTRATION and LUBRICATION

1. Dirt, scale, moisture, etc., are present in virtually every air system. Although some valves are more tolerant of these contaminants than others, best performance will be realized if a filter is installed to clean the air supply, thus preventing contaminants from interfering with the proper performance of the equipment. The ROSS Group recommends a filter with a 5-micron rating for normal applications.
2. All standard ROSS Group filters and lubricators with polycarbonate plastic bowls are designed for compressed air applications only. Use the metal bowl guard, where provided, to minimize danger from high pressure fragmentation in the event of bowl failure. Do not expose these products to certain fluids, such as alcohol or liquefied petroleum gas, as they can cause bowls to rupture, creating a combustible condition and hazardous leakage. Immediately replace crazed, cracked, or deteriorated bowls.
3. Only use lubricants which are compatible with materials used in the valves and other components in the system. Normally, compatible lubricants are petroleum base oils with oxidation inhibitors, an aniline point between 180°F (82°C) and 220°F (104°C), and an ISO 32, or lighter, viscosity. Avoid oils with

phosphate type additives which can harm polyurethane components, potentially leading to valve failure which risks personal injury, and/or damage to property.

WARNINGS:

Failure to follow these instructions can result in personal injury and/or property damage.

AVOID INTAKE/EXHAUST RESTRICTION

1. Do not restrict air flow in the supply line. To do so could reduce the pressure of the supply air below minimum requirements for the valve and thereby causing erratic action.
2. Do not restrict a valve's exhaust port as this can adversely affect its operation. Exhaust silencers must be resistant to clogging and must have flow capacities at least as great as the exhaust capacities of the valves. Contamination of the silencer can result in reduced flow and increased back pressure.

WARNINGS: Failure to follow these instructions can result in personal injury and/or property damage.

SAFETY APPLICATIONS

1. Mechanical Power Presses and other potentially hazardous machinery using a pneumatically controlled clutch and brake mechanism must use a press control double valve with a monitoring device. A double valve without a self-contained monitoring device should be used only in conjunction with a control system which assures monitoring of the valve. All double valve installations involving hazardous applications should incorporate a monitoring system which inhibits further operation of the valve and machine in the event of a failure within the valve mechanism.
2. Safe Exhaust (dump) valves without a self-contained monitoring device should be used only in conjunction with a control system which assures monitoring of the valve. All Safe Exhaust valve installations should incorporate a monitoring system which inhibits further operation of the valve and machine in the event of a failure within the valve mechanism.
3. Per specifications and regulations, the ROSS L-O-X® and L-O-X® with EEZ-ON®, N06 and N16 Series operation products are defined as energy isolation devices, NOT AS EMERGENCY STOP DEVICES.

WARNINGS:

Failure to follow these instructions can result in personal injury and/or property damage.

STANDARD WARRANTY

All products sold by the ROSS Group are warranted for a one-year period [with the exception of Filters, Regulators and Lubricators (“FRLs”) which are warranted for a period of seven (7) years] from the date of purchase. All products are, during their respective warranty periods, warranted to be free of defects in material and workmanship. The ROSS Group's obligation under this warranty is limited to repair, replacement or refund of the purchase price paid for products which the ROSS Group has determined, in its sole discretion, are defective. All warranties become void if a product has been subject to misuse, misapplication, improper maintenance, modification or tampering. Products for which warranty protection is sought must be returned to the ROSS Group freight prepaid.

THE WARRANTY EXPRESSED ABOVE IS IN LIEU OF AND EXCLUSIVE OF ALL OTHER WARRANTIES AND THE ROSS GROUP EXPRESSLY DISCLAIMS ALL OTHER WARRANTIES EITHER EXPRESSED OR IMPLIED WITH RESPECT TO MERCHANTABILITY OR FITNESS FOR A PARTICULAR PURPOSE. THE ROSS GROUP MAKES NO WARRANTY WITH RESPECT TO ITS PRODUCTS MEETING THE PROVISIONS OF ANY GOVERNMENTAL OCCUPATIONAL SAFETY AND/OR HEALTH LAWS OR REGULATIONS. IN NO EVENT IS THE ROSS GROUP LIABLE TO PURCHASER, USER, THEIR EMPLOYEES OR OTHERS FOR INCIDENTAL OR CONSEQUENTIAL DAMAGES WHICH MAY RESULT FROM A BREACH OF THE WARRANTY DESCRIBED ABOVE OR THE USE OR MISUSE OF THE PRODUCTS. NO STATEMENT OF ANY REPRESENTATIVE OR EMPLOYEE OF THE ROSS GROUP MAY EXTEND THE LIABILITY OF THE ROSS GROUP AS SET FORTH HEREIN.





AMERICAS	ROSS CONTROLS	USA	Tel: +1-248-764-1800	www.rosscontrols.com
	ROSS CONTROLS CANADA Ltd.	Canada	Tel: +1-416-251-7677	www.rosscanada.com
	ROSS DO BRASIL LTDA	Brazil	Tel: +55-11-4335-2200	www.rosscontrols.com.br
EUROPE	ROSS EUROPA GmbH	Germany	Tel: +49 (0)6103-7597-100	www.rosseuropa.com
	ROSS FRANCE SAS	France	Tel: +33-(0)1-49-45-65-65	www.rossfrance.com
	ROSS PNEUMATROL Ltd.	United Kingdom	Tel: +44 (0)1254 872277	www.rossuk.co.uk
ASIA & PACIFIC	ROSS CONTROLS INDIA Pvt. Ltd.	India	Tel: +91-44-2624-9040	www.rosscontrolsindia.com
	ROSS CONTROLS (CHINA) Ltd.	China	Tel: +86-21-6915-7961	www.rosscontrolschina.com
	ROSS ASIA K.K.	Japan	Tel: +81-42-778-7251	www.rossasia.co.jp
	AUTOMATIC VALVE INDUSTRIAL LLC	USA	Tel: +1-248-474-6700	www.automaticvalve.com
	ROSS DECCO COMPANY	USA	Tel: +1-248-764-1800	www.rossdecco.com
	ROSS PNEUMATROL Ltd.	United Kingdom	Tel: +44 (0)1254 872277	www.pneumatrol.com
	manufactIS GmbH	Germany	Tel: +49 (0)2013-16843-0	www.manufactis.net

Full-Service Global Locations

There are ROSS Distributors Throughout the World

To meet your requirements across the globe, ROSS distributors are located throughout the world. Through ROSS or its distributors, guidance is available for the selection of ROSS products, both for those using fluid power components for the first time and those designing complex systems.

Other literature is available for engineering, maintenance, and service requirements.

If you need products or specifications not shown in this catalog, please visit ROSS' website, contact ROSS or your ROSS distributor. The ROSS Support Team will be happy to assist you in selecting the best product for your application.