

Catálogo Técnico

Sensor Magnético à Prova de Explosão

Série SM-EX

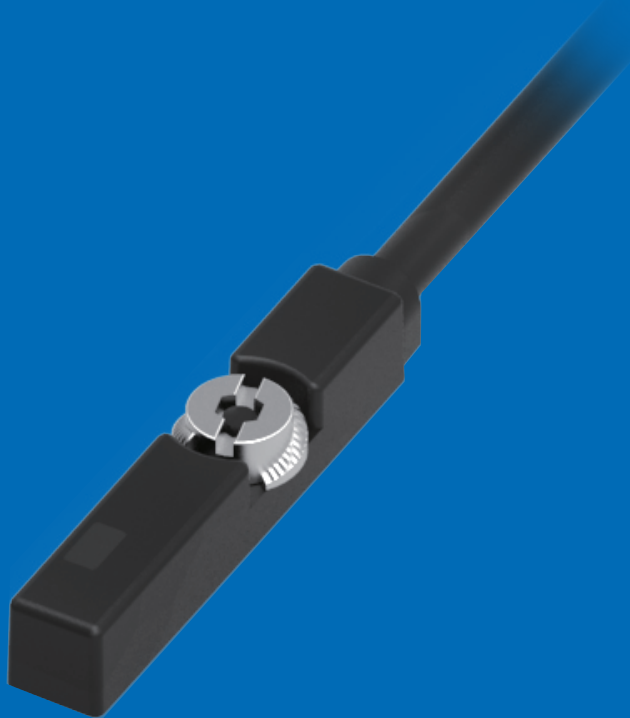

RoHS



ATEX

Sensor Magnético a Prova de Explosão - Série EX



Cilindros Aplicáveis:

- Série CP2M
- Série CGDM
- Série CGPM

Características Técnicas

	SM-65R-EX-5M	SM-65D-EX-5M	SM-65N-EX-5M	SM-65P-EX-5M	SM-65RP-EX-5M
Diagrama					
Características					
Método de Fiação	2 Fios		3 Fios		
Lógica	SPST, Normal Aberto		Solid State Output, Normal Aberto		SPST, Normal Aberto
Tipo de Sensor	Reed Switch	-	NPN	PNP	Reed Switch
Tensão de Operação	5 ~ 30 V DC / AC		10 ~ 28 V DC		10 ~ 30 V DC / AC
Corrente	100 mA max.	50 mA max.	200 mA max.		500 mA max.
Contato	10 W max.	1.5 W max.	5.5 W max.		10 W max.
Consumo Atual	-		10 mA @ 24 V DC max.		
Queda de Voltagem	3.0 V max.	3.5 V max.	1.5 V max.		0.1 V @ 100 mA max.
Fuga de Corrente	-	0.8 mA max.	0.05 mA max.		-
Indicador (LED)	Vermelho			Amarelo	
Cabo	ø2.8, 2C, PUR		ø2.8, 3C, PUR		
Frequência	200 Hz		1000 Hz		200 Hz
Exigência de Imã	65 Gauss		50 Gauss		65 Gauss
Temperatura	-10 ~ 70 °C				
Choque	30 G		50 G		30 G
Vibração	9 G				
Classificação	IEC 60529 IP67				
Circuito de Proteção	1	2	2, 3, 4		1

Ⓢ II 3GDEx ic IIB T4 Gc (-10 °C ≤ Ta ≤ +70 °C)
 II 3GDEx ic IIIC T135 °C Dc (-10 °C ≤ Ta ≤ +70 °C)



Codificação

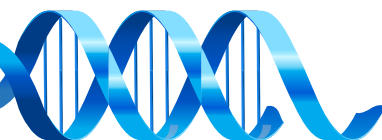
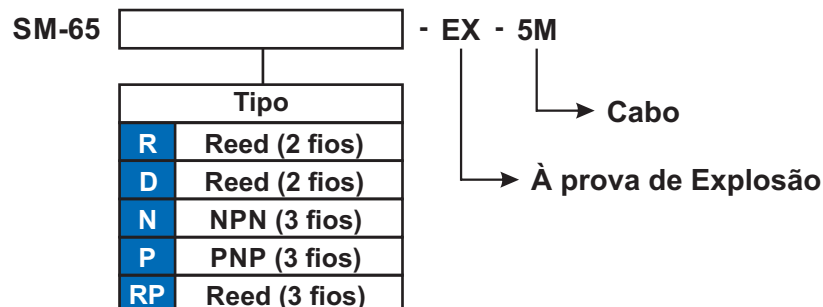

Dimensional

**SM-65N-EX-5M, SM-65P-EX-5M
SM-65D-EX-5M**

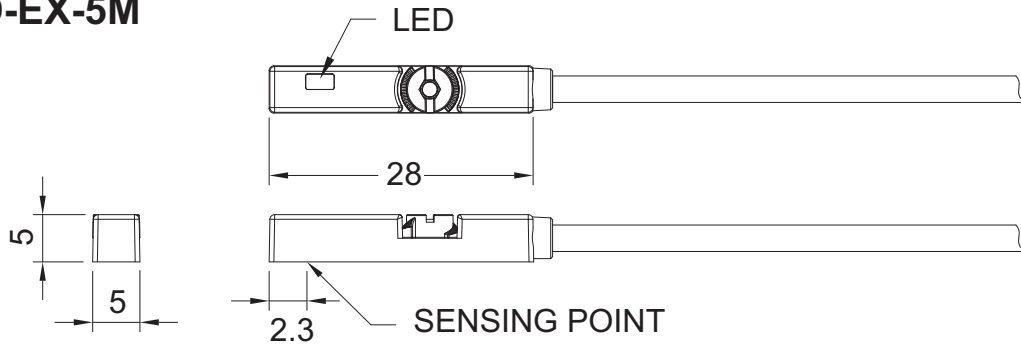

SM-65R-EX-5M, SM-65RP-EX-5M

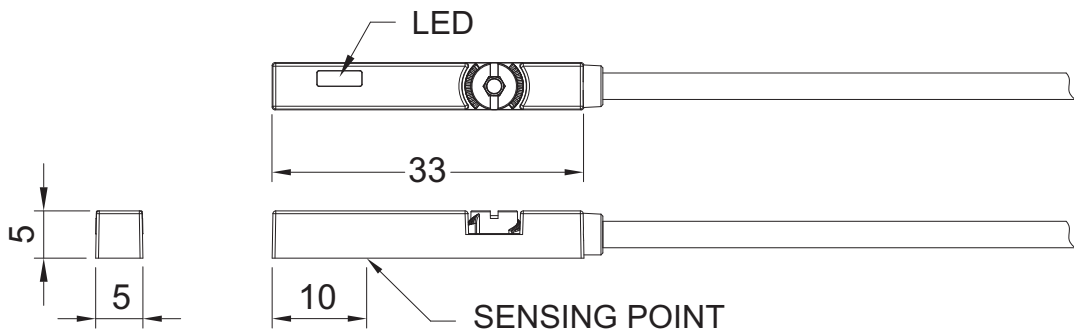

Unit : mm

Dimensional do Canal e Fixação do Sensor

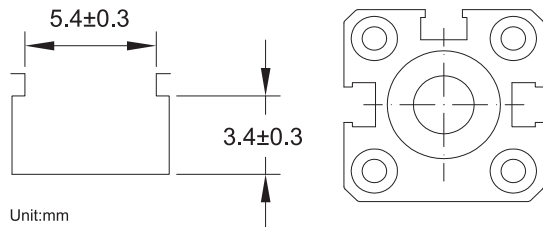

Unit:mm

